

Mod. 30 - 33 Alta Prevalenza - 55 Versione Standard
 Mod. 30 - 33 High Working head - 55 Standard Version
 Mod. 30 - 33 High Hauteur Manométrique Elevée - 55 Versione Standard
 Mod. 30 - 33 High Elevada altura manométrica - 55 Versión Standard

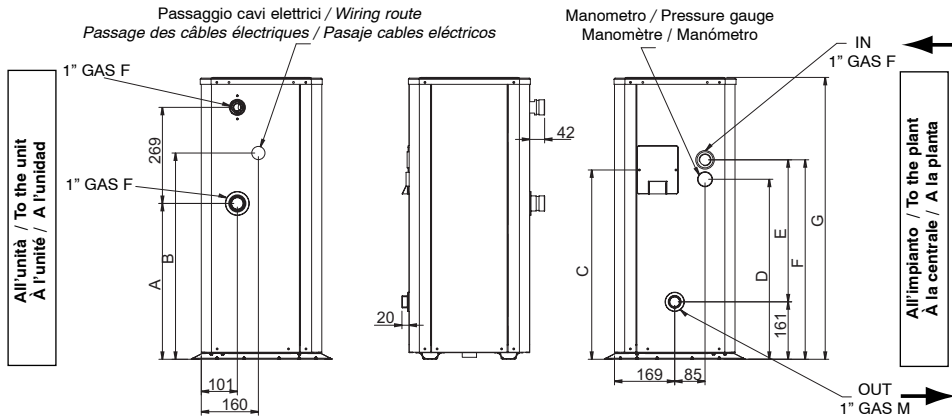

MOD	30	33	55	UM
A	437	537	787	mm
B	578	678	928	mm
C	530	630	880	mm
D	505	605	855	mm
E	398	498	748	mm
F	559	659	909	mm
G	790	890	1140	mm

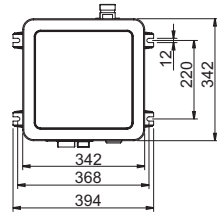

Ferrolli

SP 30 - 33 - 55

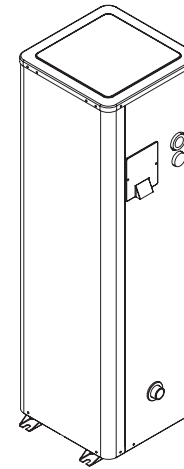

MOD. 55

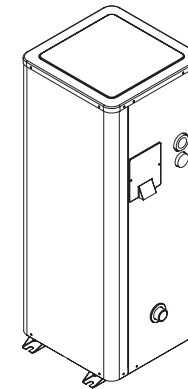

MOD. 33

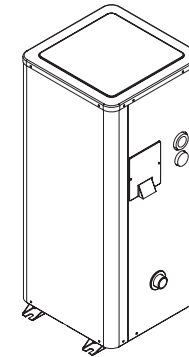

MOD. 30



- I** MODULO DI ACCUMULO E POMPAGGIO
- GB** STORAGE AND PUMPING MODULE
- F** MODULE D'ACCUMULATION ET POMPAGE
- E** MÓDULO DE ALMACENAJE Y BOMBEO

3QE19000

- I** - I dati tecnici riportati nella presente istruzione non sono impegnativi. Nell'ottica della ricerca del miglioramento continuo della propria gamma produttiva, al fine di aumentare il livello di soddisfazione del cliente, la ditta costruttrice si riserva la facoltà di apportare in qualsiasi momento tutte le modifiche ritenute necessarie.
- GB** - The technical data given in these instructions are not binding. With a view to research into continual improvement in its production range, in order to increase the level of customer satisfaction, the manufacturer reserves the right to make all the modifications considered necessary at any time.
- F** - Les données techniques indiquées dans cette instruction ne sont pas contraignantes. Dans le souci d'amélioration de sa propre gamme de production et pour augmenter le niveau de satisfaction du client, le constructeur se réserve le droit d'apporter, à tout moment, les modifications retenues nécessaires.
- E** - Los datos de las instrucciones no son vinculantes. Debido a la constante investigación para mejorar la propia gama productiva y para aumentar el nivel de satisfacción del cliente, la empresa fabricante se reserva la facultad de realizar cualquier tipo de modificación que crea necesario.

Dati tecnici generali / Main technical specifications
Données techniques générales / Datos técnicos generales

MP Versione Standard / MP Standard Version / MP Versione Standard / MP Versión Standard

Modello / Model Modèle / Modelo	30	33	55	UM
Contenuto acqua Water content Contenu d'eau Contenido agua	30	33	55	l
Capacità vaso espansione Voume of expansion tank Volume du vase d'expansion Volumen vaso de expansión	5			l
Pressione vaso di espansione Expansion tank preload pressure Pression du Vase d'expansion Presión vaso de expansión	150			kPa
Potenza massim Maximum power Puissance maximum Potencia máxima	210		450	W
Tipo di pompa Type of pump Type de pompe Tipo de bomba	CIRCOLATORE CIRCULATOR CIRCULATEUR CIRCULADOR		POMPA MULTISTADIO MULTIPLE-STAGE PUMP POMPE MULTI-ETAGE BOMBA MULTIFASE	/

MP Alta Prevalenza / MP High Working head
MP Hauteur Manométrique Elevée / MP Elevada altura manométrica

Modello / Model Modèle / Modelo	30	33	UM
Contenuto acqua Water content Contenu d'eau Contenido agua	30	33	l
Capacità vaso espansione Voume of expansion tank Volume du vase d'expansion Volumen vaso de expansión	5		l
Pressione vaso di espansione Expansion tank preload pressure Pression du Vase d'expansion Presión vaso de expansión	150		kPa
Potenza massim Maximum power Puissance maximum Potencia máxima	450		W
Tipo di pompa Type of pump Type de pompe Tipo de bomba	POMPA MULTISTADIO MULTIPLE-STAGE PUMP POMPE MULTI-ETAGE BOMBA MULTIFASE		/

Peso / Weight / Poids / Peso

Modello / Model Modèle / Modelo	30	33	55	UM
Peso di trasporto ^(NB) Transported weight ^(NB) Poids de transport ^(NB) Peso de transporte ^(NB)	39	43	54	kg
Peso in funzionamento Weight during operation Poids en service Peso en funcionamiento	67	73	105	kg

NB: Peso di trasporto comprensivo dell'imballo / **NOTE:** The transported weight includes packaging
NB : Le poids de transport comprend l'emballage / **NOTA:** El peso de transporte incluye el embalaje

SP + RXA

SP	30		33			55			
RXA	16	19	24	30	30/3	38	38/3	42	50
Versione Standard Standard Version Versione Standard Versión Standard	SAA 8		SAA 10			SAA 12			
Alta Prevalenza High Working head Hauteur Manométrique Elevée Elevada altura manométrica	SAA 9		SAA 11			-			

SP + RPC

SP	30		55		
RPC	19	30	38	42	50
Versione Standard Standard Version Versione Standard Versión Standard	SAA 8		SAA 12		
Alta Prevalenza High Working head Hauteur Manométrique Elevée Elevada altura manométrica	SAA 9		-		

Dimensioni di ingombro / Overall dimensions
Dimensions d'encombrement / Area de ocupación

Mod. 30 - 33 Versione Standard / Mod. 30 - 33 Standard Version
Mod. 30 - 33 Versione Standard / Mod. 30 - 33 Versión Standard

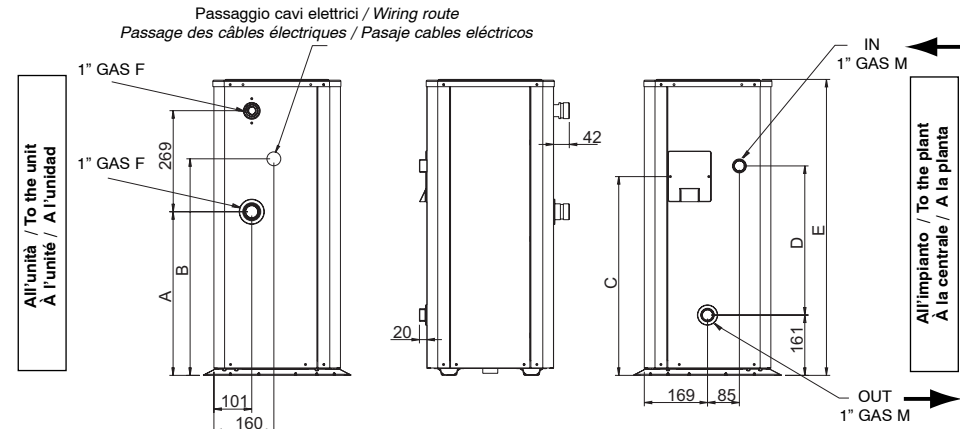

MOD	30	33	UM
A	437	537	mm
B	578	678	mm
C	530	630	mm
D	398	498	mm
E	790	890	mm

