

ferroli

TOP FAN



FERROLI adheres to the EUROVENT certification programme.
The products concerned appear in the products guide to www.eurovent-certification.com

FAN COIL

GB TECHNICAL MANUAL



CE

Dear Customer,

Thank you for having purchased a **FERROLI** Industrial coolers. It is the result of many years experience, particular research and has been made with top quality materials and highly advanced technologies. The **CE** mark guaranteed that the appliances meets European Machine Directive requirements regarding safety.

The qualitative level is kept under constant surveillance. **FERROLI** products therefore offer SAFETY, QUALITY and RELIABILITY.

Due to the continuous improvements in technologies and materials, the product specification as well as performances are subject to variations without prior notice.

Thank you once again for your preference.

FERROLI S.p.A

TABLE OF CONTENTS

DECLARATION OF CONFORMITY	4
GENERAL WARRANTY CONDITIONS	4
INTRODUCTION	5
FOREWORD	5
DESCRIPTION OF THE APPLIANCE	6
PURPOSE OF THE MACHINE	6
AVAILABLE VERSIONS AND INSTALLATION METHODS	6
GENERAL SPECIFICATIONS	9
MAIN COMPONENTS	9
DESCRIPTION OF THE COMPONENTS	10
PACKING AND CONTENTS	10
TECHNICAL SPECIFICATIONS	11
LIMITS TO OPERATION	12
SELECTION CRITERIA	12
PERFORMANCE ANALYSIS - COOLING EFFICIENCY	15
DATA CORRECTION COEFFICIENTS	15
PERFORMANCE ANALYSIS - HEATING EFFICIENCY	16
DATA CORRECTION COEFFICIENTS	16
PERFORMANCE ANALYSIS - HEATING EFFICIENCY OF SUPPLEMENTARY BANK	17
DATA CORRECTION COEFFICIENTS	17
LOAD LOSSES ON WET SIDE	18
NOISE LEVEL	19
WORKING STATIC HEAD CURVES FOR THE VN VERSION OF THE APPLIANCE	19
OVERALL DIMENSIONS OF MODEL THAT INTAKES FROM BELOW	23
OVERALL DIMENSIONS OF MODEL THAT INTAKES FROM THE FRONT	23
OVERALL DIMENSIONS OF DUCTED MODEL	24
OVERALL DIMENSIONS OF BRACKETING	24
MAIN BANK WET CONNECTIONS	25
SUPPLEMENTARY BANK WET CONNECTIONS	25
ACCESSORIES	26
TABLE OF ACCESSORY MATCHES	26
CONTROL PANEL	27
FUNCTIONS	27
DESCRIPTION OF COMMUTATOR (CM-F/CMR-F)	28
DESCRIPTION OF BASIC THERMOSTAT (TA-F/TAR-F)	28
DESCRIPTION OF UPGRADED THERMOSTAT (TA-F/TAR-F)	28
OVERALL DIMENSIONS OF CONTROL PANEL	29
TECHNICAL SPECIFICATIONS	29
INSTALLATION OPTIONS	30
OPERATING MODES	30
VENTILATION CONTROL	34
OVERALL DIMENSIONS OF BEARING FEET (PA-F)	35
OVERALL DIMENSIONS OF TRAY (BCO-F/BCV-F)	35
THREE-WAY VALVE KIT FOR TRIPLE RANK BANK VB3-F	36
TECHNICAL SPECIFICATIONS	36
KIT VB3-F VALVE LOAD LOSSES	36
THREE-WAY VALVE KIT FOR TRIPLE RANK BANK VB1-F	38
TECHNICAL SPECIFICATIONS	38
KIT VB1-F VALVE LOAD LOSSES	38
ENABLING THERMOSTAT (TC-F)	39
SUPPLEMENTARY BANK (BS-F)	39
OVERALL DIMENSIONS OF STRAIGHT DELIVERY FLANGE (FMD-F)	40
OVERALL DIMENSIONS OF PERPENDICULAR DELIVERY FLANGE (FMP-F)	40
OVERALL DIMENSIONS OF DELIVERY PLENUM (PM-F)	41
OVERALL DIMENSIONS OF STRAIGHT INTAKE FLANGE (PAD-F)	41
OVERALL DIMENSIONS OF PERPENDICULAR INTAKE FLANGE (FAP-F)	42
OVERALL DIMENSIONS OF DELIVERY GRILLE (GM-F)	42
OVERALL DIMENSIONS OF INTAKE GRILLE (GA-F)	43
OVERALL DIMENSIONS OF REAR CLOSING PANEL (PC-F)	43
ELECTRIC HEATING ELEMENT SPECIFICATIONS (RE-F)	44
DIMENSIONS OUTDOOR AIR INLET (SR-F)	44
OUTDOOR AIR INLET MOTOR (MS-F)	45
OVERALL DIMENSIONS OF INLET PLENUM (PA-F)	45
POSITIONABLE FIN KIT (AO-F)	46
CONDENSATION DISCHARGE PUMP KIT (PSC-F)	46
ELECTRICAL CONNECTIONS	47
KEY TO WIRING DIAGRAMS	47
WIRING DIAGRAMS	48

DECLARATION OF CONFORMITY

The company hereby declares that the machine in question complies with the matters prescribed by the following Directives:

- Machine Directive **98/73 EEC**
- Low voltage Directive **72/23 EEC**
- Electromagnetic compatibility Directive **EMC 89/36 EEC**

The manufacturer is associated with the
EUROVENT certification program.
The products are listed in the certified products
guide www.eurovent-certification.com



GENERAL WARRANTY CONDITIONS

The manufacturer guarantees the appliances sold.

The warranty covers material and/or manufacturing defects.

The warranty runs from the date on which the appliance is delivered, as attested by the receipt or consignment note.

The warranty terms only become valid and operative when the appliance starts work within 1 (one) year from the date of manufacture at most.

Interventions covered by the warranty shall not modify the duration of the warranty itself or the date from which it runs.

Parts replaced under guarantee are the property of the manufacturer to which they must be returned at the user's care and expense.

The owner of the appliance shall be obliged to pay the call charge for each intervention requested unless this latter takes place in a **Technical Assistance Center** authorized by the manufacturer, the appliance has been taken there at the owner's charge and expense and has also been collected by the same.

- WARRANTY EXCLUSIONS:

• Parts damaged through transport, incorrect INSTALLATION, incorrect sizing, improper use or use in heavy-duty and critical conditions that jeopardize the appliance, through tampering by unauthorized persons, through wear (seals, knobs, warning lights, etc.) and in any case through causes beyond the manufacturer's control.

- FAILURE TO COMPLY WITH THE FOLLOWING INSTRUCTIONS SHALL VOID THE WARRANTY:

• The products must be installed in a workmanlike manner and in compliance with the laws in force in the country in which the appliance is installed:

- PERFORMANCES NOT COVERED BY THE WARRANTY:

• Once the warranty terms have elapsed, technical assistance will be provided by charging the user for any parts replaced, all the labour, travel and travelling allowance expenses sustained by the personnel and for the materials, according to the tariffs in force the moment the assistance is provided.

- LIABILITY:

• The personnel authorized by the manufacturer provides technical assistance for the user. The installer is the person solely responsible for the installation and must comply with the technical instructions given in the installer's manual.

• This warranty shall never include the obligation to reimburse damages of any nature sustained by persons or property.

• No one is authorized to modify the terms of this warranty or to issue other verbal or written guarantees.

• Competent court in the event of disputes: Verona.

INTRODUCTION

FOREWORD

This is one of the two manuals supplied with the machine in question. Some of the manuals are dedicated to the end user, others to the installer, thus the information they contain and their purposes are different. The following table gives the subjects discussed in the two manuals:

Tab.1

SUBJECTS	MANUALS	
	TECHNICIAN ⁽¹⁾	INSTALLATION AND USE
General information:	•	•
Features		
Description of the machine, versions, accessories	•	
Technical specifications	•	
Technical data	•	
Dimensional data	•	•
Accessory data	•	
Wiring diagrams	•	•
Safety measures:		•
General precautions		•
Improper uses		•
INSTALLATION:		•
Transport		•
How to INSTALL the appliance		•
Setting at work		•
Operation		•
Routine maintenance		•
Assistance and spares		•
Troubleshooting		•

(1): Not supplied with the machine

Keep the manual in a dry place so that it remains in a good condition for several years (10), ready to hand for future reference when required.

Carefully read all the information in this manual. Pay particular attention to the operation instructions marked with the words “DANGER” or “WARNING” since failure to comply with such instructions can cause damage to the machine and/or to persons or property.

Contact your nearest assistance center for any faults not described in this manual.

The manufacturer declines all liability for damage caused by improper use of the machine, or due to the information in this manual having been partially or superficially read.

Besides the matters described on the warranty certificate, failure to comply with the instructions herein or inadequate installation of the machine may oblige the manufacturer to void the warranty supplied.

DESCRIPTION OF THE APPLIANCE

PURPOSE OF THE MACHINE

The convector fan is an appliance that treats the air in the room in both summer (bank supplied with cold water) and winter (bank supplied with hot water).

AVAILABLE VERSIONS AND INSTALLATION METHODS

The range of centrifugal convector fans includes three versions. Different power ratings are available for each.

1: VM-B - Convactor fan with cabinet and intake from below

Fig.1

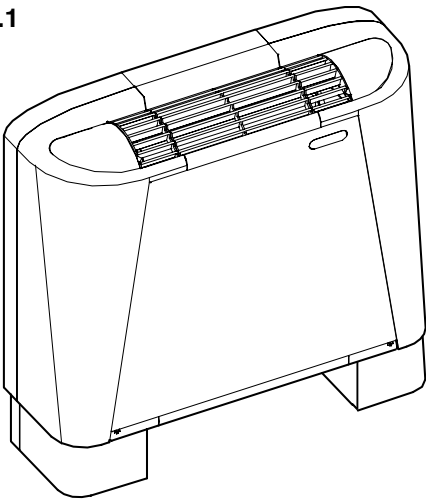

Consists of a sheet metal cabinet, a delivery grille with doors to access the panel (if applicable) made of thermoplastic material plus an air filter that can be re-generated, installed on a metal frame with covering profile in plastic material housed on guides formed in the lower part of the frame.

- Installation mode

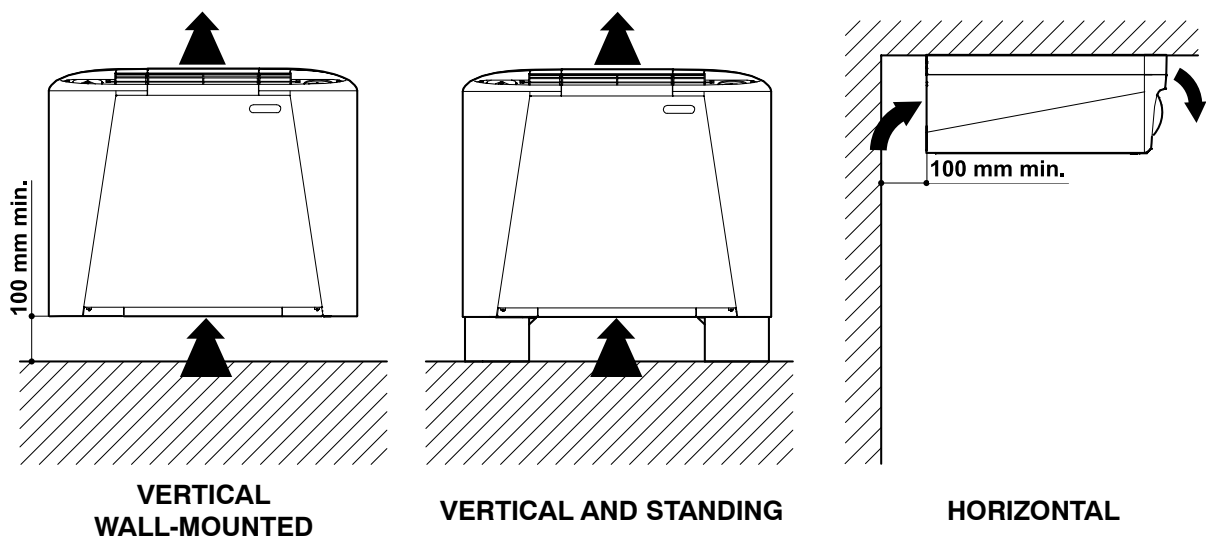
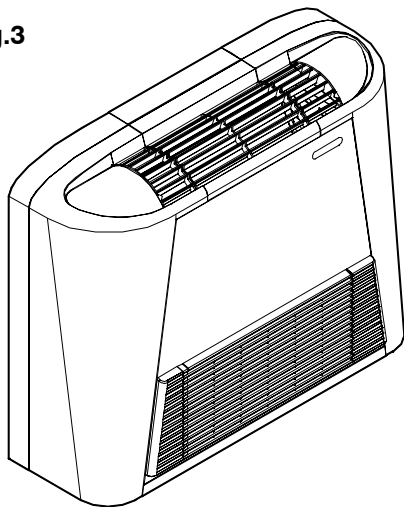

Fig.2

DESCRIPTION OF THE APPLIANCE

2: VM-F - Convecteur fan with cabinet and frontal intake

Fig.3



Consisting of a sheet metal cabinet, a delivery grille with doors to access a panel if installed in thermoplastic material, plus an air filter that can be re-generated installed in the front grille, made of plastic material and sheet metal and closing at the bottom.

- Installation mode

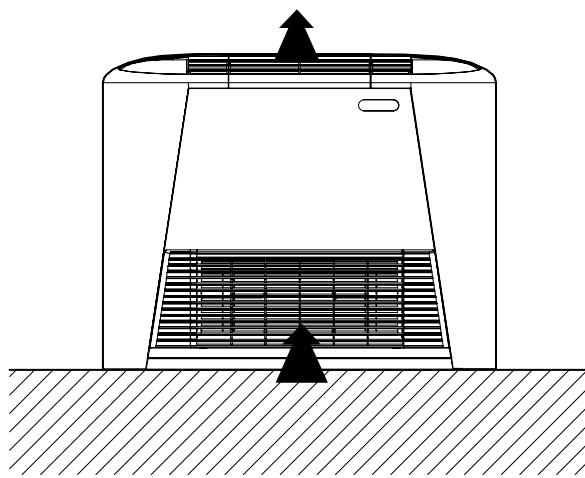

VERTICAL WALL-MOUNTED

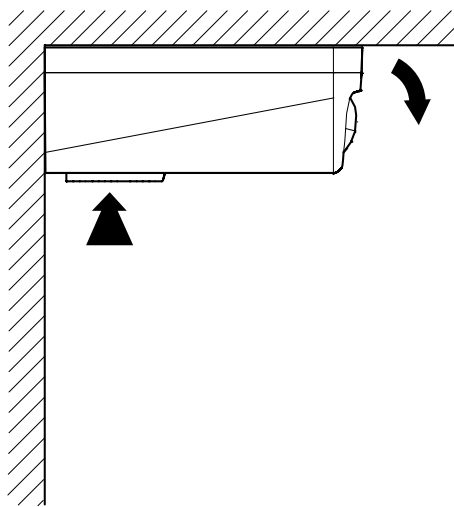

HORIZONTAL ON CEILING

Fig.4

DESCRIPTION OF THE APPLIANCE

3: VN - Convactor fan without cabinet for built-in installation

Fig.5

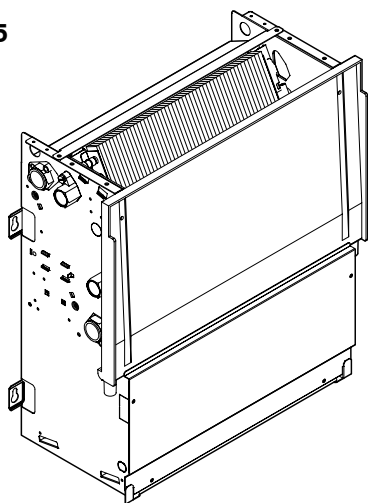

Without cabinet. Includes a filter which can be re-generated, mounted on a metal frame with covering profile in plastic material. It can be fitted with a series of accessories to suit the installation requirements (e.g. **plenum, flanges, unions**). These are described in the **ACCESSORIES** Section of this manual.

- Installation mode

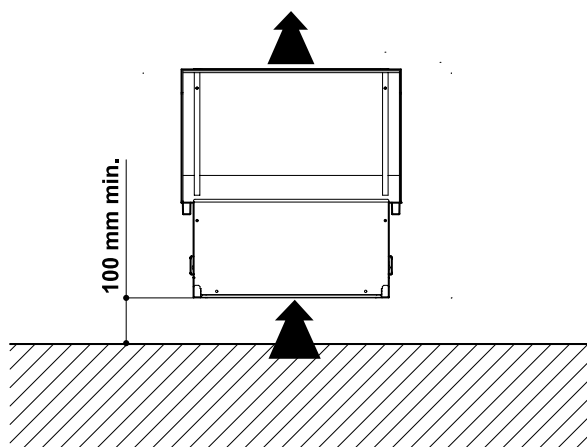

VERTICAL INSTALLATION

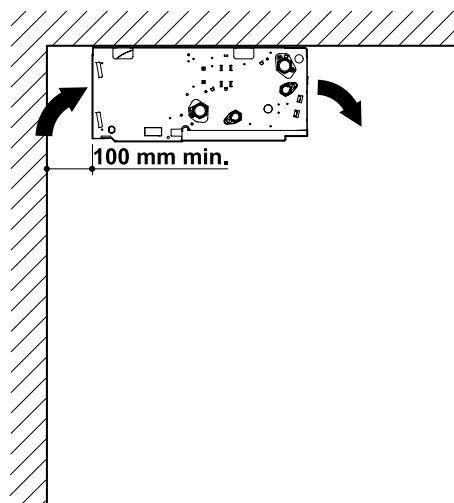

HORIZONTAL ON CEILING

Fig.6

GENERAL SPECIFICATIONS

MAIN COMPONENTS

The following table lists the main components that form the appliance:

COMPONENTS	
1 Wet connections	6 Condensation tray
2 Exchange bank	7 Motor and fan
3 Air filter	8 Control panel (if installed)
4 Cabinet	
5 Bearing structure	

Drawing of VM-F version

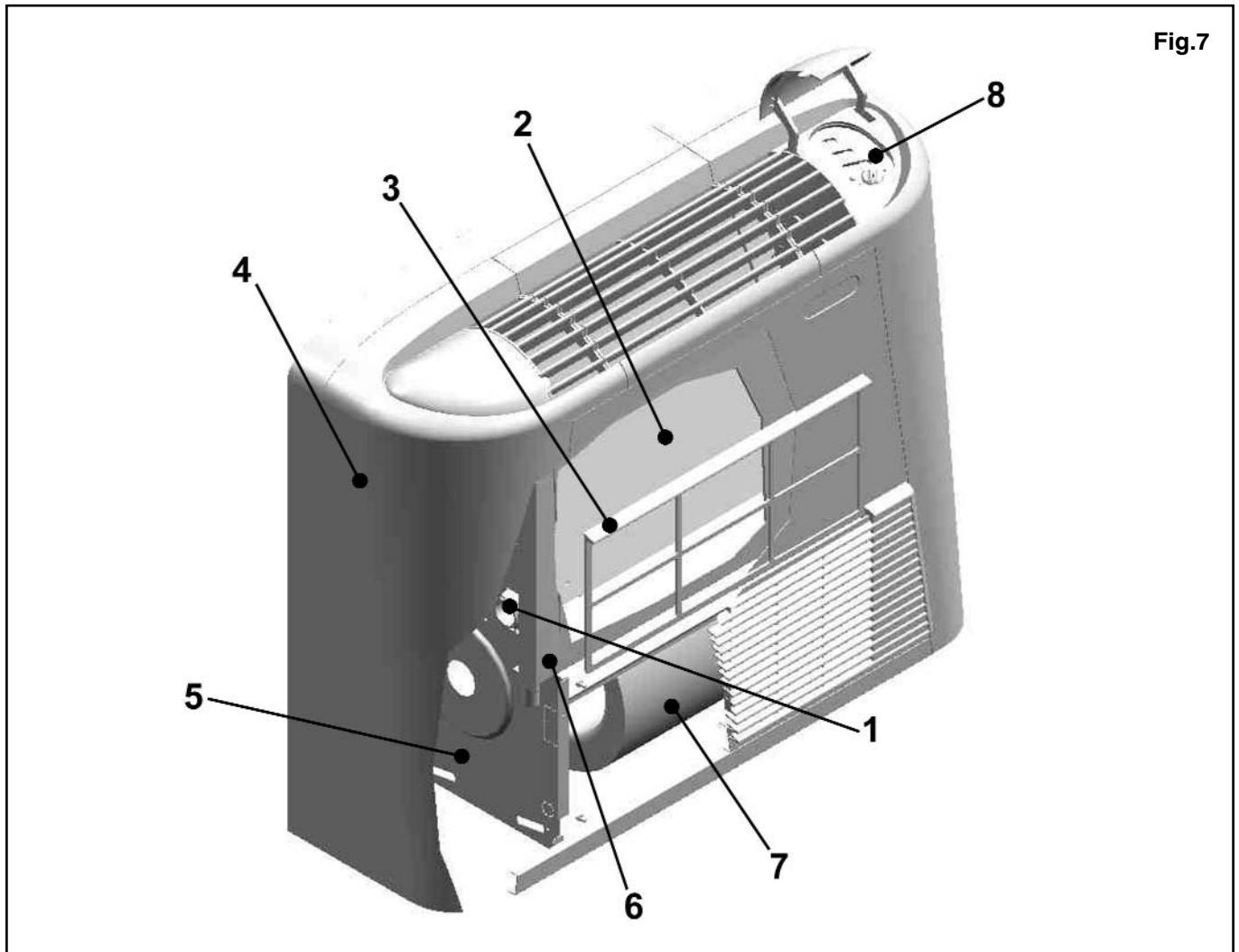

GENERAL SPECIFICATIONS

DESCRIPTION OF COMPONENTS

1. Heat exchange bank

Bank with 3 ranks made of copper pipe and aluminium finning locked together by mechanical expansion of the pipes. The manifolds in the upper part of the bank are equipped with air vents while the ones in the lower part have holes to drain out the water. Both manifolds have a housing for the temperature probe of the feed water.

2. Air filter

Can be easily removed and regenerated by simply washing in water.

3. Cabinet

Partly made of steel sheet coated with epoxy powder paint to ensure a high resistance to rust, and partly of **anti-UV** thermoplastic material to protect against ultraviolet rays.

VM-B version: there are grilles to distribute the air in the upper part and a door to access the control panel. Both are made of **anti-UV** thermoplastic material.

VM-F version: there are grilles to distribute the air in the upper part and a door to access the control panel. Both are made of **anti-UV** thermoplastic material.

The cabinet also has a front grille made of **anti-UV** thermoplastic material which takes in the air.

4. Bearing structure

Made of adequately thick galvanized sheet metal. The rear part has slots to fix the appliance in place. Models without cabinets are covered at the front by a panel to protect the ventilating unit.

5. Condensation tray

Made of thermoplastic material to prevent rust from forming. Allows the machine to be installed either vertically or horizontally. Thanks to its shape, the drops of condensation that form on the manifolds when the appliance is operating in cold mode are collected in the tray when the machine is installed horizontally. The condensation is then eliminated from the tray which is installed on both sides of the appliance so that the bank can be turned if necessary.

6. Fan motor

The electric motor is protected against overloads, has three speed settings, infinitely engaged capacitor, is directly coupled to the fans and has elastic shock-absorbing supports. Centrifugal series: has centrifugal fans with double intake and long blades to achieve a high flow rate at a low rpm rate.

7. Wet connections

Positioned on the left-hand side, the connections are the $\frac{3}{4}$ " type. The bank can be turned if necessary.

8. Control panel (described in the **ACCESSORIES** section of this manual)

PACKING AND CONTENTS

The convector fans are shipped in standard packaging consisting of a cardboard box inside which angular pieces of cardboard are fitted to protect the appliance from damage during the handling phase. The cardboard box contains:

- 1 convector fan
- 1 cardboard template for assembly purposes
- Instruction manuals

GENERAL SPECIFICATIONS

TECHNICAL SPECIFICATIONS

Tab.2

MODEL		15	20	30	40	50	60	80	100	120
Heating Capacity	Max. W	2800	3650	5500	6500	7800	9400	12500	14900	15800
	Med. W	2400	3150	4550	5450	6600	7900	10800	12500	13270
	Min. W	1800	2250	3400	4000	4930	5800	8300	9600	10000
Water flow rate	l/h	241	314	473	559	671	808	1075	1281	1359
Water pressure drop ^(E)	Kpa	5.1	8.6	17.6	24.2	14	18.1	17.7	10.8	12.1
Heating Capacity ^{(E)(1)}	W	1700	2050	3200	3850	4590	5100	7200	8700	9300
Water pressure drop ^(E)	Kpa	3.6	5.3	11.3	20.1	13.0	14.6	15	8.0	10.1
Cooling Capacity	Max. W ^(E)	1100	1400	2100	2800	3400	4000	4900	6100	6850
	Med. W	980	1200	1850	2450	3010	3550	4350	5500	6100
	Min. W	770	950	1450	1900	2390	2800	3600	4400	5000
Water flow rate ^(E)	l/h	189	241	361	482	585	688	843	1049	1178
Dehumidifying	max speed g/h	230	275	500	650	750	870	930	1160	1350
Water pressure drop ^(E)	Kpa	4.4	6.9	14.6	23	14	18	14.9	9.9	12.5
Heating capacity of supplementary bank	Max. W ^(E)	1250	1650	2550	3150	3690	4100	5050	6200	6950
	Med. W	1070	1420	2110	2640	3150	3440	4360	5200	6190
	Min. W	860	1130	1750	2150	2320	2820	3480	4250	4800
Water flow rate	l/h	108	142	219	271	317	353	434	533	598
Water pressure drop	Kpa	1.7	3	8.6	13.2	3.0	4.1	6.2	12.8	16.1
Heating capacity of heat.el.	W	800	800	1500	1500	2200	2200	2200	2600	2600
Ari flow rate	Max. m ³ /h	215	280	410	515	615	750	1050	1200	1350
	Med. m ³ /h	170	210	310	400	510	600	850	970	1070
	Min. m ³ /h	110	140	220	290	350	410	570	670	720
N° fans		1	1	1	2	2	2	2	3	3
Sound power level	Max. dB(A) ^(E)	47	48	52	54	53	55	64	63	65
	Med. dB(A) ^(E)	42	42	45	47	46	50	58	59	60
	Min. dB(A) ^(E)	32	38	40	41	37	39	48	51	52
Sound pressure level ⁽²⁾	Max. dB(A)	38	39	43	45	44	46	55	54	56
	Med. dB(A)	33	33	36	38	37	41	49	50	51
	Min. dB(A)	23	29	31	32	28	30	39	42	43
Potenza max.motore ^(E)	W	35	38	55	76	75	85	144	163	200
Main coil connections	Ø	3/4"	3/4"	3/4"	3/4"	3/4"	3/4"	3/4"	3/4"	3/4"
Secondary coil connections	Ø	1/2"	1/2"	1/2"	1/2"	1/2"	1/2"	1/2"	1/2"	1/2"
3R bank water contents	l	0.82	0.82	1.26	1.26	1.88	1.88	1.88	2.42	2.42
1R bank water contents	l	0.22	0.22	0.36	0.36	0.50	0.50	0.50	0.64	0.64
Condensation draining connections	Ø	16	16	16	16	16	16	16	16	16

NOTES:

Power source voltage rating: 230-1-50 [V-F-Hz]

Heating mode:

• Ambient air temp.: 20°C.

• Inlet water temp.: 70°C, water Δt 10°C at top fan speed; water flow rate same as top speed at medium and minimum fan speeds.

• (1) Inlet water temp. 50°C water flow rate as in cooling mode.

Fan speed: max

Cooling mode:

• Ambient air temp.: 27°C D.B. 19°C W.B

• Inlet water temp.: 7°C, water Δt 5°C at top fan speed; water flow rate same as top speed at medium and minimum fan speeds.

• Fan speed: max

(2) Sound pressure in 100 m³ room with 0.5 sec reverberation time.

(E) EUROVENT certified data

GENERAL SPECIFICATIONS

LIMITS TO OPERATION

The main limits to operation for the appliances in question are given in the following table:

Tab.3

MODEL		15	20	30	40	50	60	80	100	120
Max. temperature limits (°C)		85	85	85	85	85	85	85	85	85
Max pressure limits(bar)		8	8	8	8	8	8	8	8	8
Main bank flow rate limits	Min.flow r.(l/h)	100	100	100	100	150	150	200	300	300
	Max.flow r.(l/h)	700	700	800	800	1100	1100	1400	2100	2100
Secondary bank flow rate limits	Min.flow r.(l/h)	50	50	50	50	100	100	100	100	100
	Max.flow r.(l/h)	350	350	350	350	700	700	700	700	700

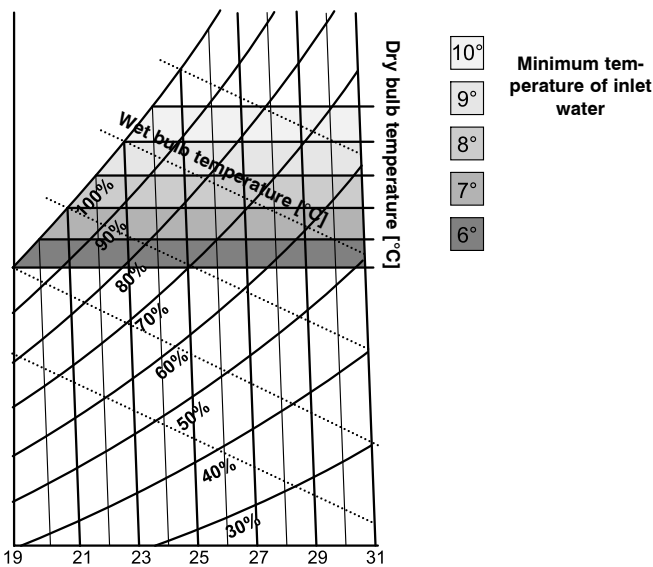

To prevent condensation from forming on the external structure of the appliance, the minimum temperature of the water must not be lower than the limits given in the graph on the left, which depend on the **thermo-hygrometric** conditions of the surrounding air. The above limits refer to operation at minimum speed.

SELECTION CRITERIA

- Configuration:

The convector fan series with centrifugal ventilator includes three versions: **VM-B** with cabinet and intake from below, **VM-F** with cabinet and frontal intake and lastly, **VN** without cabinet for built-in or ceiling-mounted installation. Depending on the specific installation requirements, select the version required in compliance with the indications in **Figs 1 to 6**. The particular shape of the condensation tray allows the same appliances to be installed either vertically or horizontally. All units are produced with wet couplings on the left-hand side and the electric part on the opposite side as standard supply. If the position of the wet couplings must be inverted, the units and set of available accessories are pre-engineered for this operation which is described in detail in the installation manual. There is a wide range of accessories for the various units, allowing these latter to be configured to suit the most varied plant layouts. The list of available accessories and their compatibility with the various versions and sizes is given in **Tab.10** which is followed by a brief description of the actual accessories themselves.

- Technical specifications:

Tab.2 gives the significant values of the units in the nominal operating conditions mentioned in the table itself. Refer to the enclosed tables with the individual parameters if the operating conditions differ.

Selection examples:

An example of how a unit is selected is given in order to describe how to use the graphs or tables in the manuals. The configuration of the unit is obviously bound to the type of system envisaged, thus the selection will be made considering that the unit will operate in the same conditions as those given for different types of system. The following applications will therefore be considered:

- A) system with two pipes for heating and cooling
- B) system with four pipes
- C) system with two pipes plus electric heating element
- D) system with two pipes and ducted unit.

Example 1

The convector fan must guarantee the following specifications:

Total refrigerating capacity **2700 [Watt]**

Sensible refrigerating capacity **2100 [Watt]**

Operating ambient temperature **27 [°C] b.s** and **19 [°C] b.u**

The value must be obtained at **medium speed**.

Thermal power **4000 [Watt]**

Operating ambient temperature **20 [°C] b.s**

Water flow rate as in cold mode for two units.

The value must be obtained at **medium speed**.

GENERAL SPECIFICATIONS

- **Option A** (unit for system with two pipes)

The technical data concerning efficiency in both the heating and cooling modes are given considering that the unit is operated at maximum fan speed. Adequate corrective coefficients can be used to determine the efficiency ratings at the medium and minimum speeds. In order to use **Graphs 1 and 2**, calculate the parameters of the requested values considering top speed operation.

Use **Tab.4**

Total refrigerating capacity required at top speed **Pft max = 2700/0.88 = 3070 [Watt]**

Sensible refrigerating capacity required at top speed **Pft max = 2100/0.84 = 2500 [Watt]**

Graph 1 gives the model most able to obtain these efficiency ratings, i.e. model **40**, which obtains these efficiency ratings with a **6[°C]** inlet water temperature and a Δt of **5[°C]** or **7[°C]** and a Δt of **4[°C]**, or with an **8[°C]** water inlet temperature and a Δt of **3[°C]**.

Supposing that water enters the convector fan at **7[°C]** and the Δt is **4[°C]**: the water flow rate must be:

$$Q_w = \frac{Pft_{max}}{\Delta t \cdot \rho_{w1} \cdot cp_{w1}} = \frac{3070 \cdot 3600}{4 \cdot 1 \cdot 4192} = 659 [l/h]$$

where:

Qw= Water flow rate [l/h]

Δw1= Density of the water at 10 °C [Kg/dm³]

Cpw1= Specific heat of the water at 10°C [J/kg·K]

This water flow rate obtains the expected efficiency ratings at medium speed while in this case, the effective Δt will be:

$$\Delta t = \frac{Pft_{med}}{Q_w \cdot \rho_{w1} \cdot cp_{w1}} = \frac{2700 \cdot 3600}{659 \cdot 1 \cdot 4192} = 3.5 [°C]$$

Graph 4 allows the relative load losses to be calculated. In this specific case, these are **35[KPa]**.

If the load losses were incompatible with the pump characteristics, the version with a **6 °C** water inlet temperature and Δt of **5°C** could be used. This would obtain a water flow rate of **527[l/h]** instead of **659 [l/h]** and a **4.4 [°C]** effective Δt at an average speed of **4.4 [°C]**. In this case, **Graph 4** gives a load loss of **25 [KPa]**.

If valve kit **VB3-F** is used, the additional load losses with the unit powered shown in **Graph 14** are **6 [KPa]** in the first condition and **4 [KPa]** in the second condition.

The optimum temperature at which the convector fan must be fed must now be found in order to obtain the required thermal power. It is reasonable to suppose that a system with two tubes operates with the same flow rate as calculated for cold mode operation. Here again, the parameters of the required power must be re-calculated considering that the fan operates at top speed. Use **Tab.5**.

Thermal power required at top speed **Pt max = 4000/0.85 = 4700 [Watt]**

In this case, the required Δt can be easily calculated since both the flow rate and efficiency values have already been established. Supposing that the flow rate is **527 [l/h]**, one obtains:

$$\Delta t = \frac{Pt_{max}}{Q_w \cdot \rho_{w2} \cdot cp_{w2}} = \frac{4700 \cdot 3600}{527 \cdot 0.98 \cdot 4180} = 7.8 [°C]$$

where:

Qw= Water flow rate [l/h]

Δw2= Water density at 60 °C [Kg/dm³]

Cpw2= Specific heat of the water at 60°C [J/kg·K]

In this case, **Graph 2** shows that to obtain the power required with the selected model **40**, the convector fan must be supplied with water at a temperature of about **58 [°C]**. As shown in **Tab.4** attached to **Graph 4**, note that the load losses are less than those obtained in cold mode by a factor of about **0.77**. It is therefore logical to expect a higher water flow rate than the one estimated if the circuit pump characteristics are to remain the same. In this case, the water flow for which the load losses are **25 [KPa]** is about **650 [l/h]**, as can be seen from the same graph.

Tab.9 can thus be used to calculate the value of the noise generated by the selected unit which, as mentioned previously, is model **40** operating at medium speed, thus an acoustic power of **47 dB[A]** and a corresponding sound pressure of **38 dB[A]**, measured according to the indicated conditions.

GENERAL SPECIFICATIONS

- **Option B** (unit for system with 4 pipes)

The considerations made for selection **A** are also valid when it comes to selecting for cold mode operation. In this case, evaluate how to supply supplementary bank **BS-F2** envisaged as optional. Remember that the information in the documentation refers to the top speed of the fan, thus the required efficiency parameter must be calculated again.

Use **Tab.6** attached to **Graph 3**

Thermal power required at top speed **Pt max = 4000/0.85 = 4700 [Watt]**

Graph 3 shows that with an ambient air temperature of **20 [°C]**, model **40** is unable to supply this power even when supplied with water at **85 [°C]** and with a minimum **Δt** of about **5 [°C]**. In these conditions, the maximum power delivered by the unit at top speed is **4300 [Watt]**. Once this solution has been accepted, **Graph 3** shows that the required **4000 [Watt]** power can be obtained with an inlet water temperature of **85[°C]** and a **Δt** of **16[°C]** or with an inlet temperature of **80[°C]** and a **5[°C]** **Δt**. The second hypothesis requires the following water flow rate:

$$Q_w = \frac{P_{ft_{max}}}{\Delta t \cdot \rho_{w3} \cdot c_{p_{w3}}} = \frac{4000 \cdot 3600}{5 \cdot 0.97 \cdot 4196} = 707 [l/h]$$

Qw= Water flow rate [l/h]

Δw3= Water density at 80 °C [Kg/dm³]

Cpw3= Specific heat of the water at 80°C [J/kg·K]

This water flow rate is not compatible with the application limits given in **Tab.3**. If the solution with inlet water at the temperature of **85[°C]** and a **Δt** of **16[°C]** is used, the water flow rate should be **221 [l/h]**. In this case, the load loss of the exchanger in model **BS-F2** can be found by means of **Graph 5** and is **10 [KPa]**. If valve kit **VB1-F** is used, the additional load losses with the unit supplied would be shown by **Graph 15** and are **4 [KPa]**.

At this stage, **Tab.9** can be used to find the noise level produced by the selected unit (i.e. model **40**) operating at medium speed in cold mode and at top speed in heating mode. This corresponds to an acoustic power rating of **47 dB[A]** and a corresponding sound pressure of **38 dB[A]** measured in cold mode operation in the indicated conditions; with an acoustic power rating of **54 dB[A]** and with a corresponding acoustic pressure of **45 dB[A]** for operation in heating mode, again measured in the indicated conditions.

- **Option C** (unit for systems with two pipes plus electric heating element)

Here again, selection for cold mode operation is the same as described for selection **A**. When it comes to operation in heating mode and if the electric heating element is used as sole source of heat, the maximum power it delivers can be found in the **Tab.** attached to **Fig.33** concerning model **RE-F2**, which can be used with model **40** and is **1500 [Watt]**, and which does not depend on the fan speed. In this case, the **4000 Watt** required can only be obtained by integrating the power supplied by the electric heating element with the power supplied by the main bank fed with hot water. Upgraded electronic thermostats **TE-F** and **TER-F** allow the electric power delivery to be controlled by integrating the two sources or by selecting the electric heating element as single heat source. This option can be selected in the installation phase by means of the dip switches on the thermostats. If the electric heating element is used as integrating source, it will activate when the temperature of the water drops below **40 [°C]**.

- **Option D** (unit for systems with two pipes for ducted installation)

Let us suppose that the unit must be installed in a false ceiling and that the air intake and delivery sections must be ducted. The considerations made in example **A** for both cold and heating mode operation should be taken into account when the most appropriate model is chosen. After this, the motor should be examined to ensure that the fan is able to account for the load losses introduced by the air ducting system. Given the initial power delivery and fan speed conditions, model **40** at an average speed processes **400 [m³/h]** of air, as shown in **Tab.2**. Supposing that the overall ducting system, including any intake grilles mounted, the intake channel, delivery plenum, delivery channel and delivery grille is around **45 [Pa]** with an air flow rate of **400 [m³/h]** and also considering that in the dehumidifying phase the additional load loss in the exchanger is about **4 [Pa]** as shown by the dotted curve in **Graph9**, this same graph also shows that the most appropriate electrical connection to obtain that working head is connection **L-2** rather than connection **L-4** indicated by boldface and corresponding to the standard connection envisaged for the medium speed. This means that the red and blue connection flexes for the maximum and medium speeds must be respectively moved to positions 1 and 2.

GENERAL SPECIFICATIONS

PERFORMANCE ANALYSIS - COOLING EFFICIENCY

Graph 1 gives an analysis of the cooling performances in operating conditions differing from the nominal ones. The values given refer to the maximum fan speed. The values corresponding to the medium and minimum speeds can be found by applying the corresponding corrective coefficients given in the table below.

NOTE: Efficiency values that are sensibly higher than the total efficiency should be interpreted as an absence of dehumidification. In this case, only the sensible efficiency values should be considered.

Graph1

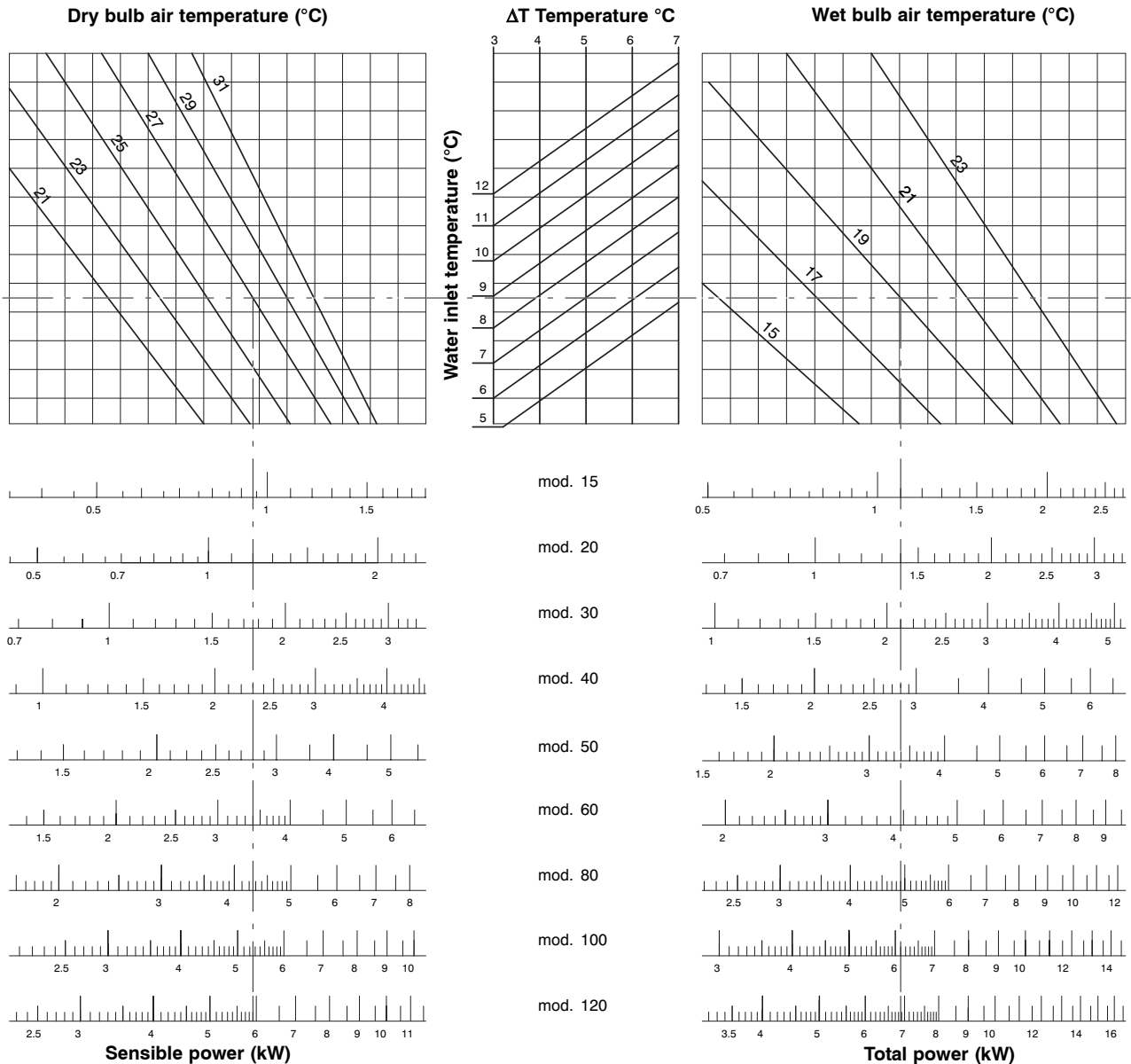

DATA CORRECTION COEFFICIENTS

If the unit operates at the same temperature as the inlet water, the water flow rate is envisaged at maximum speed. The efficiency ratings obtained at speeds differing from the maximum one are calculated according to the following corrective coefficients:

Fan speed	Sensible refrigerating efficiency	Total refrigerating efficiency
Vmax.	1	1
Vmed.	0.84	0.88
Vmin.	0.62	0.67

Tab.4

GENERAL SPECIFICATIONS

PERFORMANCE ANALYSIS - HEATING EFFICIENCY

Graph 2 gives an analysis of the cooling performances in operating conditions differing from the nominal ones. The values given refer to the maximum fan speed. The values corresponding to the medium and minimum speeds can be found by applying the corresponding corrective coefficients given in the table below.

Graph 2

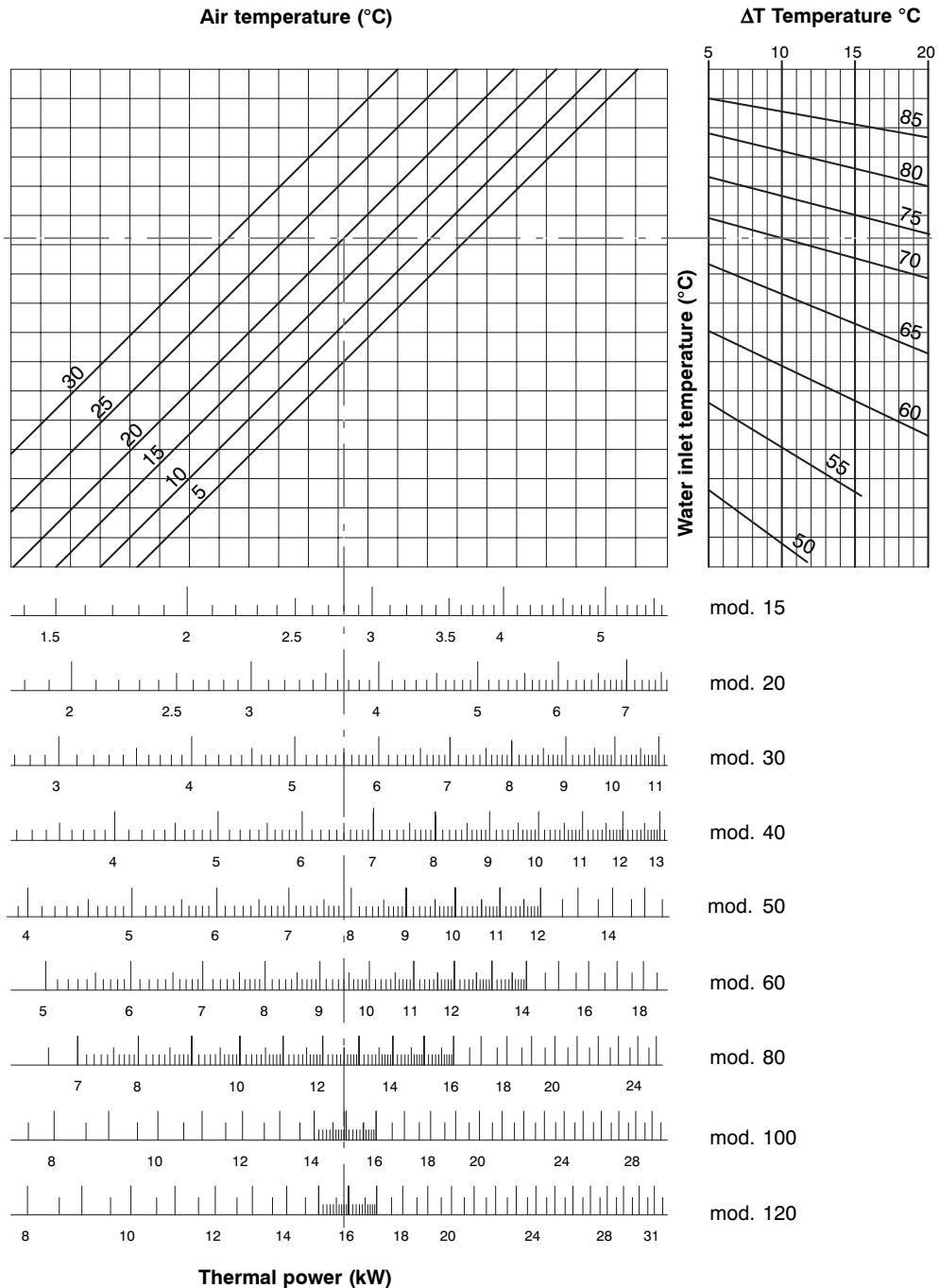

DATA CORRECTION COEFFICIENTS

If the unit operates at the same temperature as the inlet water, the water flow rate is envisaged at maximum speed. The efficiency ratings obtained at speeds differing from the maximum one are calculated according to the following corrective coefficients:

Fan speed	Heating efficiency
Vmax.	1
Vmed.	0.85
Vmin.	0.63

Tab.5

GENERAL SPECIFICATIONS

PERFORMANCE ANALYSIS - HEATING EFFICIENCY OF SUPPLEMENTARY BANK

Graph 3 gives an analysis of the cooling performances in operating conditions differing from the nominal ones. The values given refer to the maximum fan speed. The values corresponding to the medium and minimum speeds can be found by applying the corresponding corrective coefficients given in the table below.

Graph 3

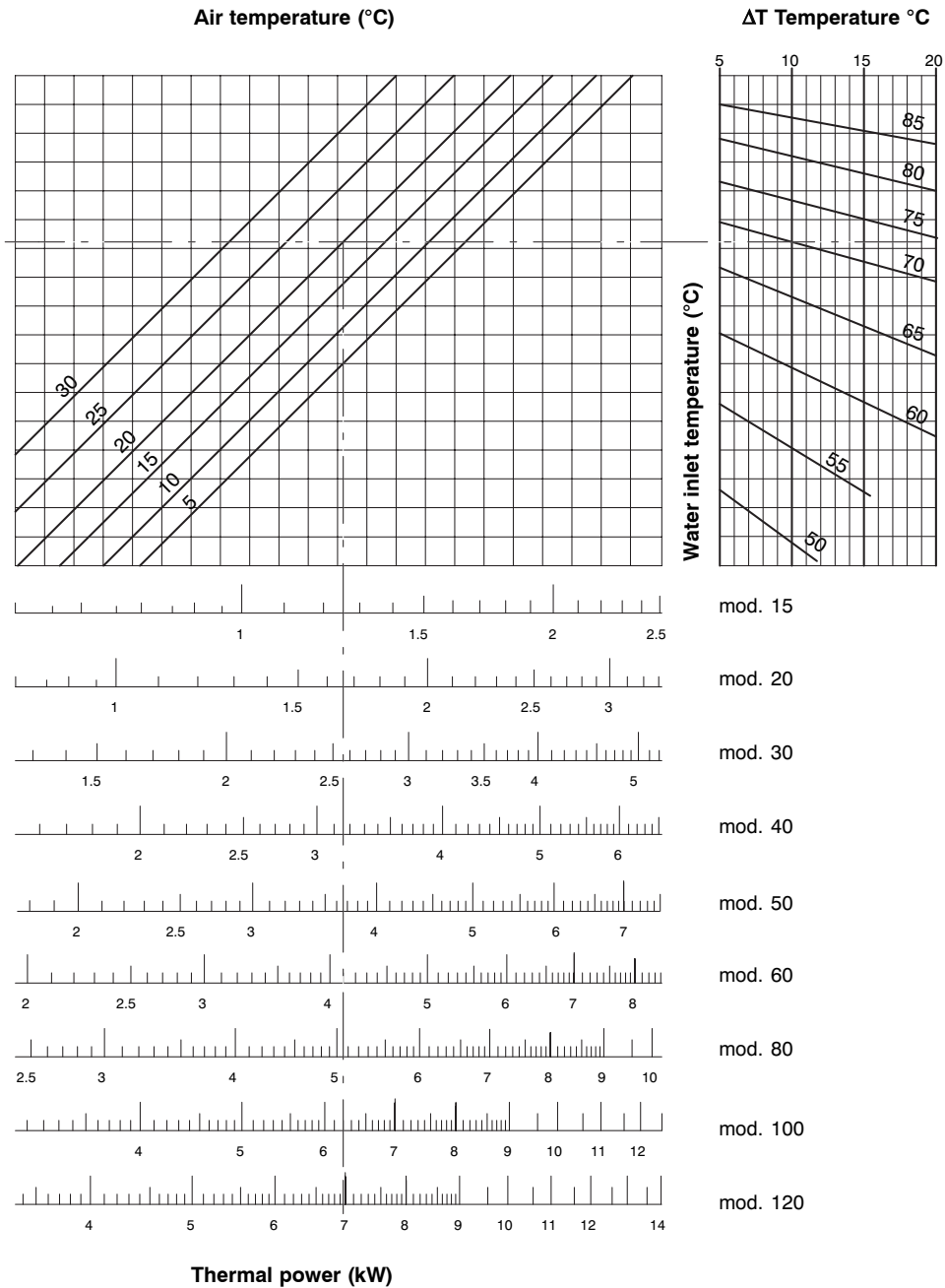

DATA CORRECTION COEFFICIENTS

If the unit operates at the same temperature as the inlet water, the water flow rate is envisaged at maximum speed. The efficiency ratings obtained at speeds differing from the maximum one are calculated according to the following corrective coefficients:

Fan speed	Heating efficiency
Vmax.	1
Vmed.	0.85
Vmin.	0.69

Tab.6

GENERAL SPECIFICATIONS

LOAD LOSSES ON WET SIDE

The following graph gives the load losses measured on the triple rank bank installed in the fancoil unit.

Graph 4

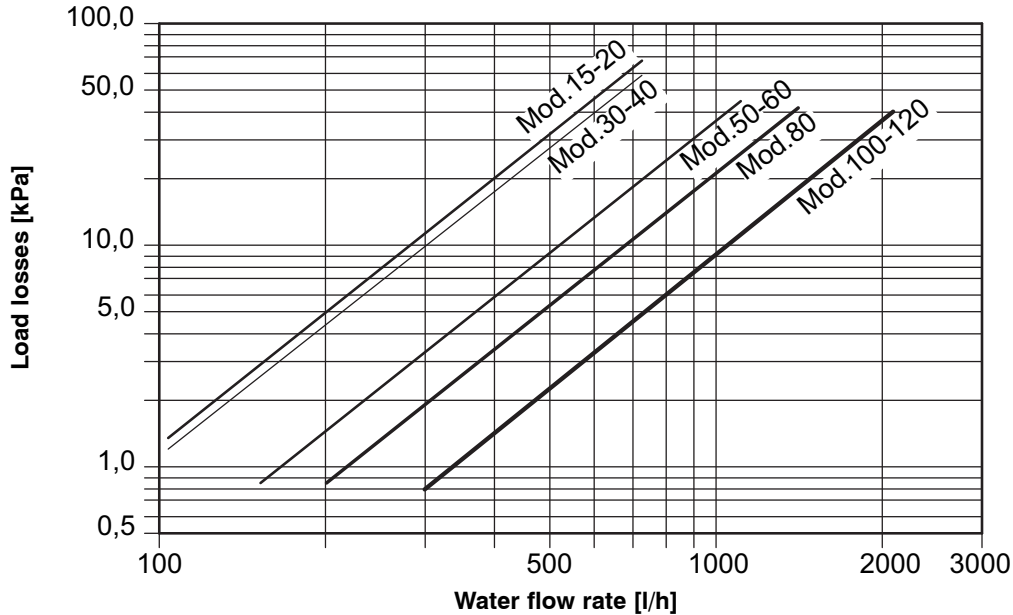

The load losses shown in the previous figure concern an average water temperature of 10°C. The table below gives the loss correction factors measured as the average temperature varies.

Tab.7

Average H ₂ O temperature	5	10	15	20	50	60	70
Corrective coefficient	1.05	1.0	0.97	0.95	0.8	0.75	0.71

Graph 5 gives the load loss values measured in the single-rank bank envisaged as optional on the fancoil unit:

Graph 5

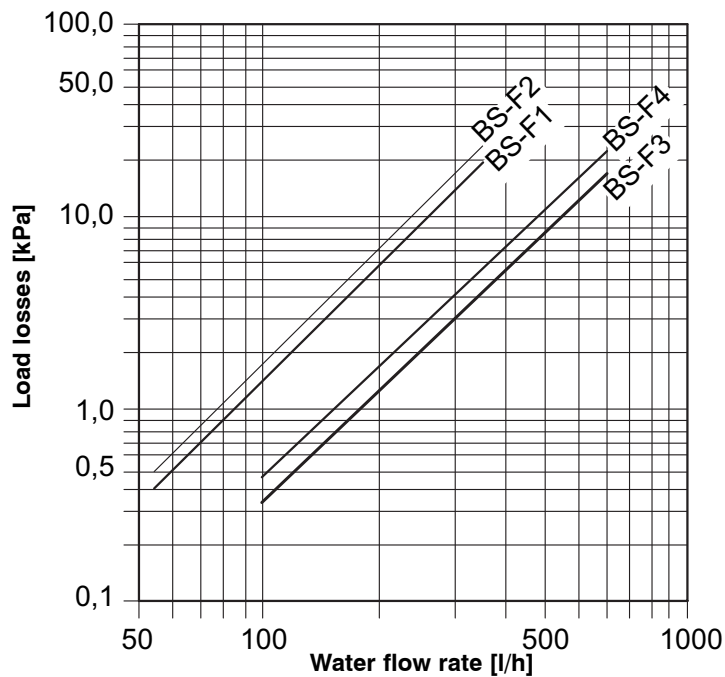

The load losses shown in the previous figure concern an average water temperature of 70°C. The table below gives the loss correction factors measured as the average temperature varies.

Tab.8

Average H ₂ O temperature	50	60	70
Corrective coefficient	1.10	1.05	1.0

GENERAL SPECIFICATIONS

NOISE LEVEL

The following table (**Tab.9**) gives the noise level performances of the entire fancoil range expressed as acoustic power level. The last column gives the acoustic pressure level in a 100 m³ room with a 0.5 second reverberation time.

Tab.9

Model	Speed	Potenza sonora [dB(A)]									Acoustic pressure dB(A)
		Central band frequency [Hz]							Global		
		125	250	500	1000	2000	4000	8000	dB	dB(A)	
15	Max	39,7	43,1	46,8	41,2	35,3	28,7	26,8	50	47	38
	Med	38,1	39,8	41,6	37,3	26,3	17,2	9,3	46	42	33
	Min	30,8	33,7	32,3	25,3	16,7	9,7	4,8	38	32	23
20	Max	42,1	45,9	47,9	43,7	38,5	32,1	22,5	52	48	39
	Med	35,6	40,2	41,8	37,2	27,8	19,7	12	45	42	33
	Min	35,3	37,5	38,2	31,2	24,5	15,3	6,9	42	38	29
30	Max	44,8	50,9	50,1	47,3	44,6	37,7	29,5	55	52	43
	Med	42	45	44,4	38,2	35,4	29,6	21,4	49	45	36
	Min	39	41,2	39,3	32,5	28,7	24,1	17	45	40	31
40	Max	47,4	50,6	52,3	49,2	46,1	40,7	32,7	57	54	45
	Med	43,2	46,2	46,9	42,1	37,8	30	23	51	47	38
	Min	38,6	41,3	41	35,2	29,7	21,3	16,5	46	41	32
50	Max	49,7	52,4	50,4	48,3	43,4	37,7	31,3	57	53	44
	Med	44,6	47,6	44,9	41,3	36,5	29,6	24,1	51	46	37
	Min	37,2	39,7	36,3	31,2	26,6	21,2	19,2	43	37	28
60	Max	51,1	53,6	54,7	48,5	44	36,8	27,2	59	55	46
	Med	45,6	48,9	49,8	43,6	37,9	27,4	21,9	54	50	41
	Min	36,6	42,2	39	31	23,9	19,7	19,4	45	39	30
80	Max	57,6	59,3	61,8	59,4	55,1	50,6	43,1	66	64	55
	Med	53,7	56	57	52,5	48,8	42,3	33,3	61	58	49
	Min	44,4	48,3	48,3	41,9	35,9	27,4	21,2	53	48	39
100	Max	59	61,1	61,2	57,7	55	51,2	43	66	63	54
	Med	55,2	57,3	57,6	53,4	49,8	43,4	33,9	63	59	50
	Min	47,2	50,1	50,8	44,7	39,6	31,6	23,9	55	51	42
130	Max	59,7	62,6	62,5	59,9	57,6	52,9	46,4	68	65	56
	Med	55,8	58,1	58,8	55,2	52,1	46,2	38	64	60	51
	Min	48	50,7	51,4	46,2	41,6	33,8	24,6	56	52	43

WORKING STATIC HEAD CURVES FOR THE VN VERSION OF THE APPLIANCE

The convector fans in the **VN** series are equipped with six-speed motors. The most appropriate connection can be chosen depending on the working head. The graphs given in the following pages show the working head depending on the flow rate and according to the selected electrical connection. The units leave the production line with the electrical connections shown in **Fig.8**. The indicated head includes the load losses of the sole bank and filter supplied with the units. If these latter operate in dehumidifying mode with wet banks, the dotted line gives the additional load losses and, thus, the relative reduction in working static head. Each graph also gives a curve showing how the total refrigerating efficiency varies as the air flow rate changes. Depending on plant requirements, the electrical connections can be modified in order to vary the flow rate/head ratio of the motor. With reference to the curves given below and once the most appropriate connection has been selected, work on the autotransformer directly connected to the motor for models up to 40 or on the transmission terminal board for larger models. During these operations in the autotransformer, the faston of the connection cable must be moved from the main terminal board of the actual autotransformer itself and fitted into the most appropriate of the positions numbered 1 to 6 on its data plate. In models **60 ÷ 120**, this operation must be carried out in the transmission terminal board installed between the motor and the main terminal board. Here again, the connection cable must be moved to the most appropriate of the positions marked 1 to 6 in the data plate.

Fig.8

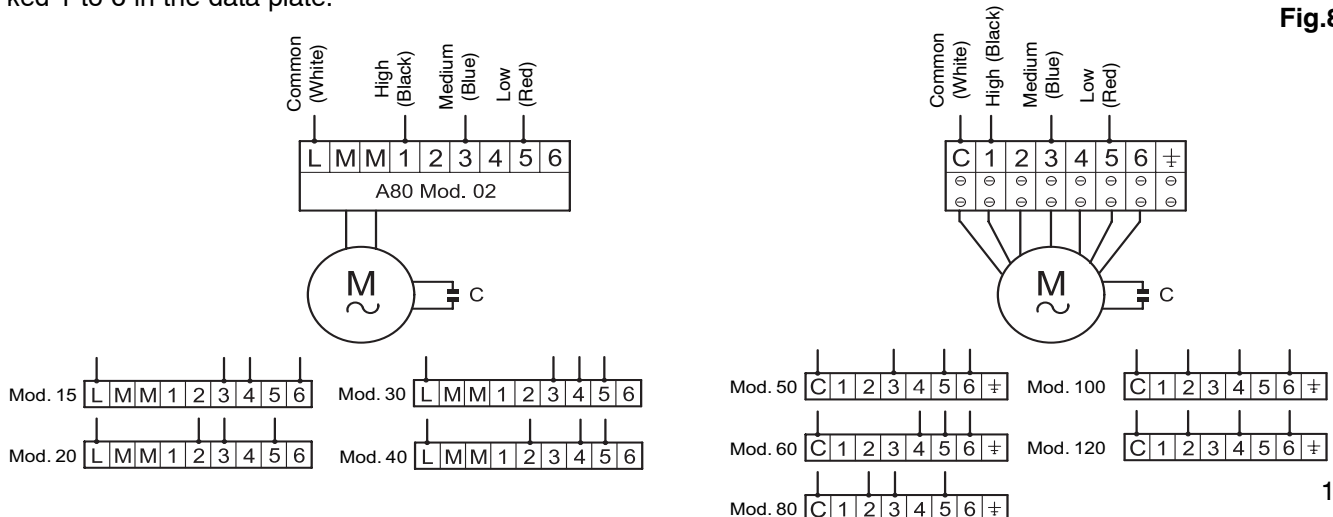

GENERAL SPECIFICATIONS

VERSION VN HEAD CURVES (Mod.15)

Graph 6

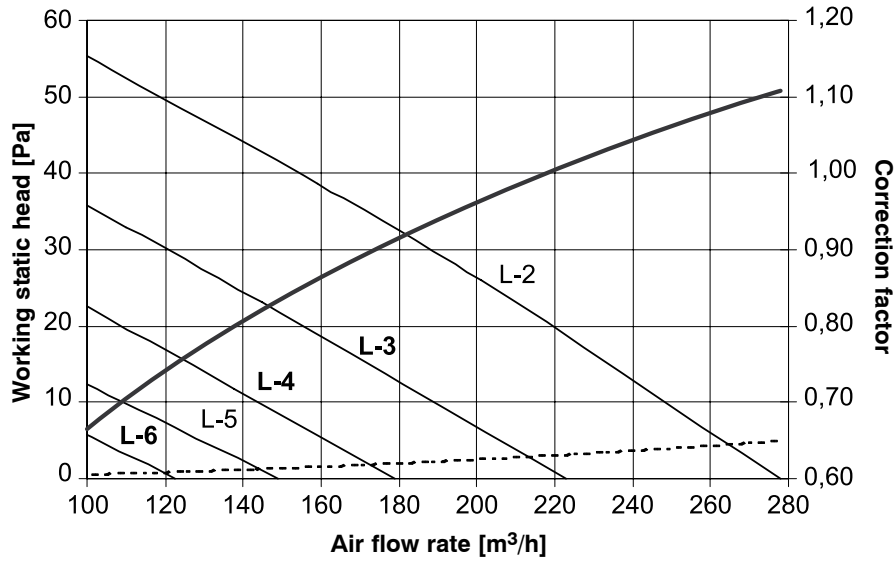

VERSION VN HEAD CURVES (Mod.20)

Graph 7

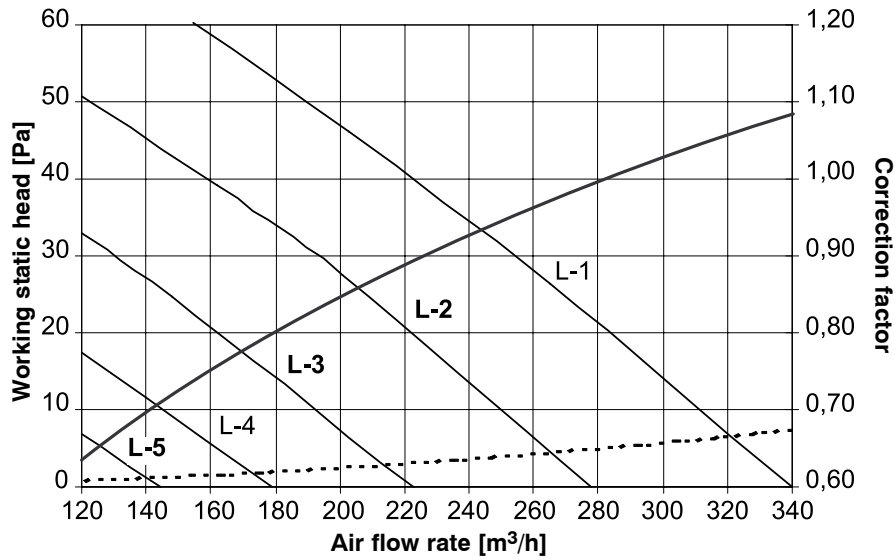

VERSION VN HEAD CURVES (Mod.30)

Graph 8

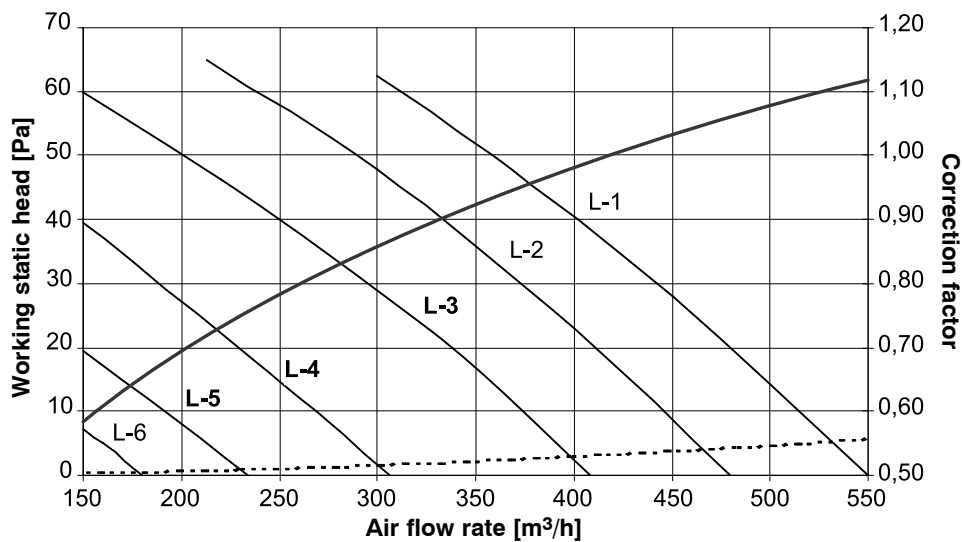

GENERAL SPECIFICATIONS

VERSION VN HEAD CURVES (Mod.40)

Graph 9

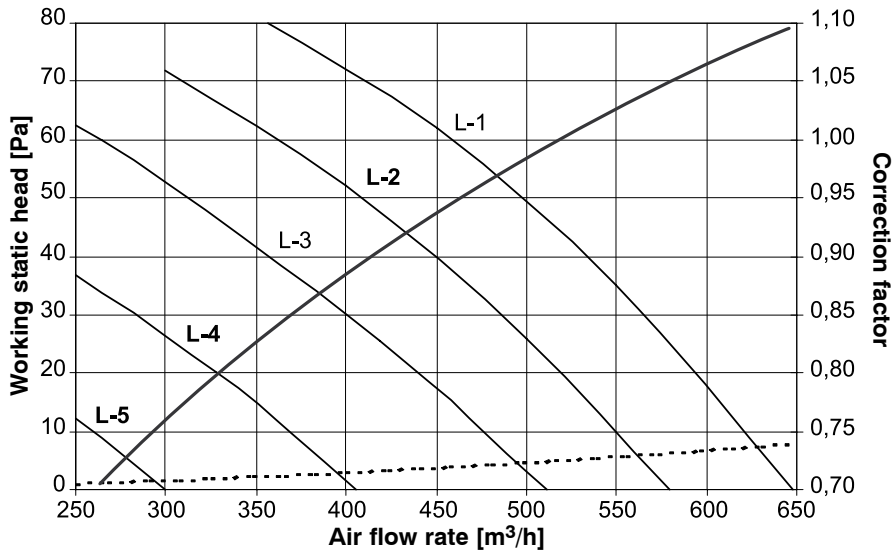

VERSION VN HEAD CURVES (Mod.50)

Graph 10

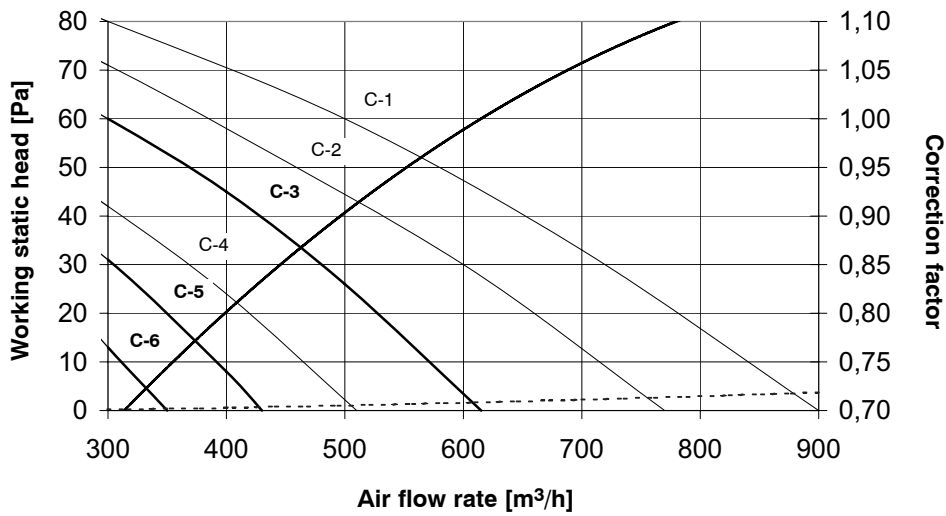

VERSION VN HEAD CURVES (Mod.60)

Graph 11

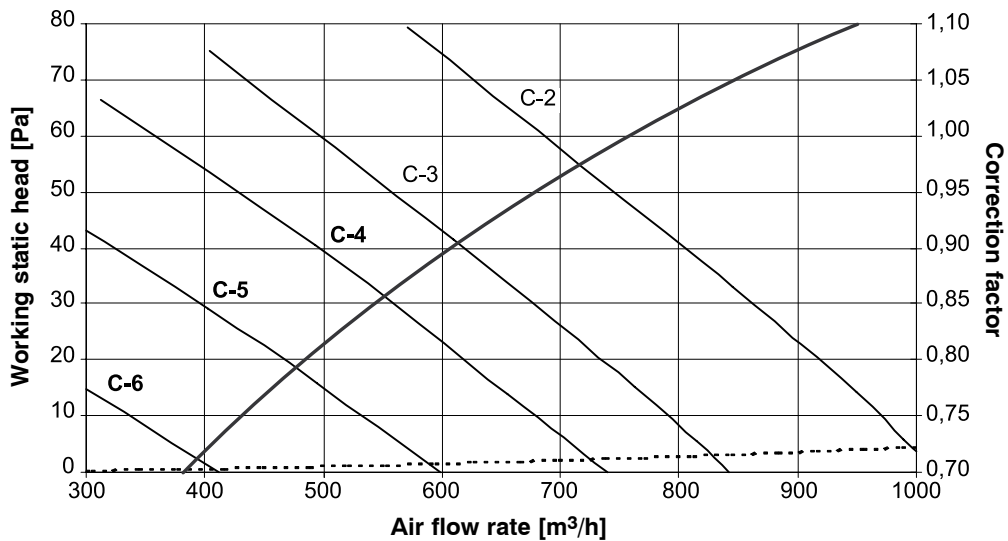

GENERAL SPECIFICATIONS

VERSION VN HEAD CURVES (Mod.80)

Graph 12

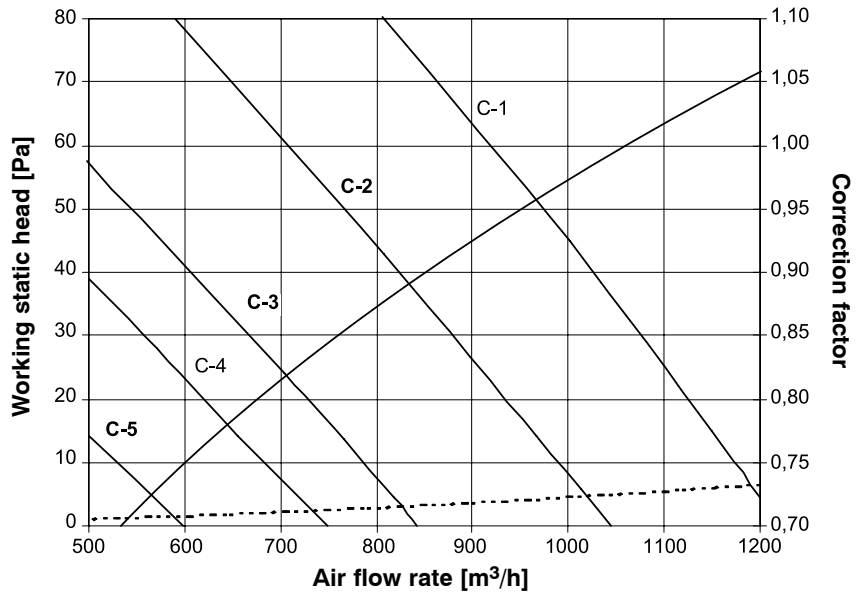

VERSION VN HEAD CURVES (Mod.100)

Graph 13

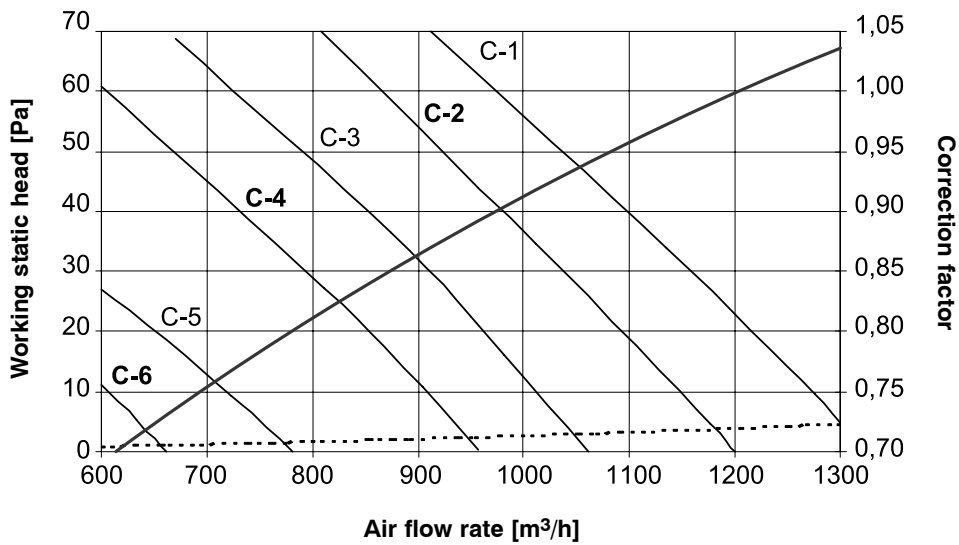

VERSION VN HEAD CURVES (Mod.120)

Graph 14

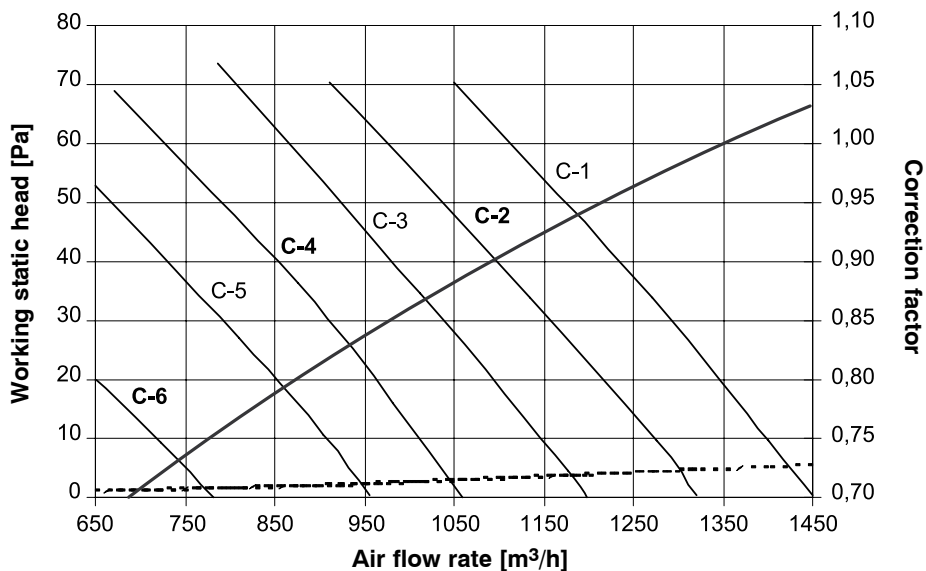

GENERAL SPECIFICATIONS

OVERALL DIMENSIONS OF MODEL THAT INTAKES FROM BELOW

Fig.9

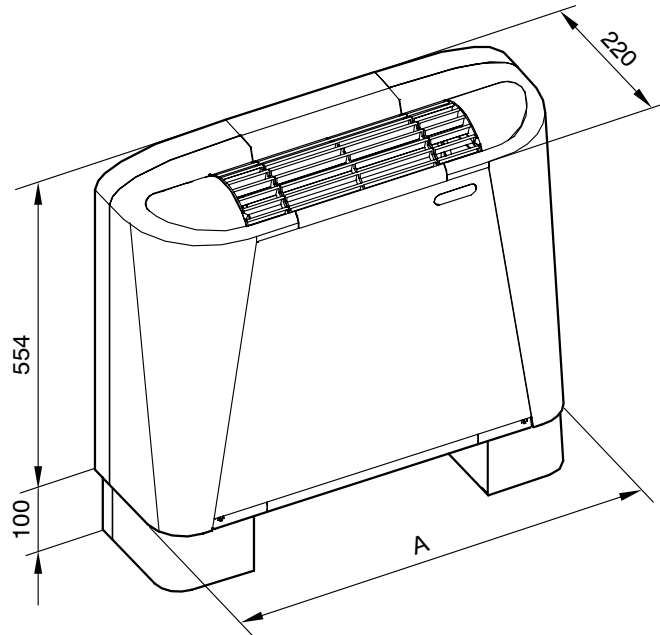

MODEL	15	20	30	40	50	60	80	100	120
A (mm)	690	690	940	940	1190	1190	1190	1440	1440
Weight (Kg)	14	14	20	20	27	27	27	34	34

OVERALL DIMENSIONS OF MODEL THAT INTAKES FROM THE FRONT

Fig.10

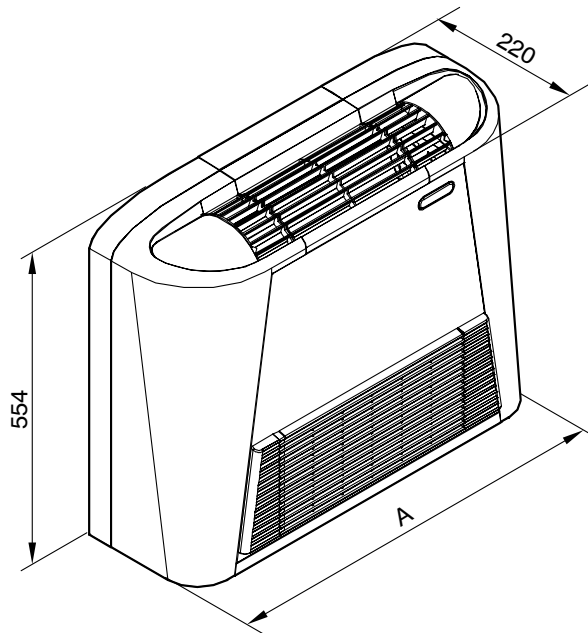

MODEL	15	20	30	40	50	60	80	100	120
A (mm)	690	690	940	940	1190	1190	1190	1440	1440
Weight (Kg)	15	15	21	21	28	28	28	36	36

GENERAL SPECIFICATIONS

OVERALL DIMENSIONS OF DUCTED MODEL

Fig.11

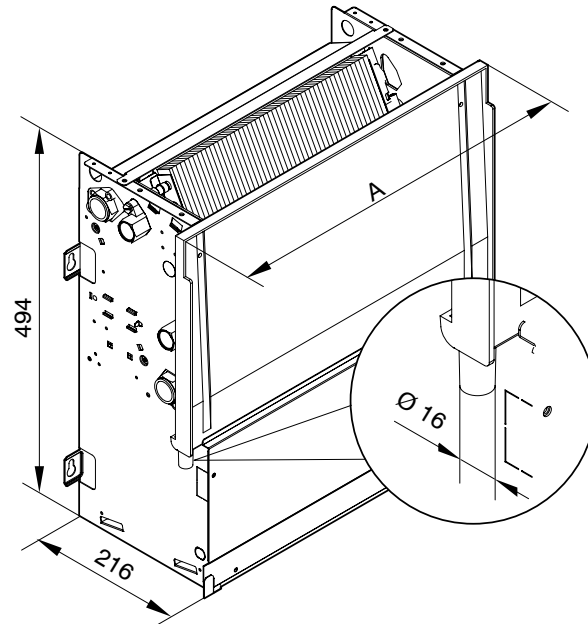

MODEL	15	20	30	40	50	60	80	100	120
A (mm)	474	474	724	724	974	974	974	1224	1224
Weight (Kg)	11	11	15	15	22	22	22	29	29

OVERALL DIMENSIONS OF BRACKETING

Fig.12

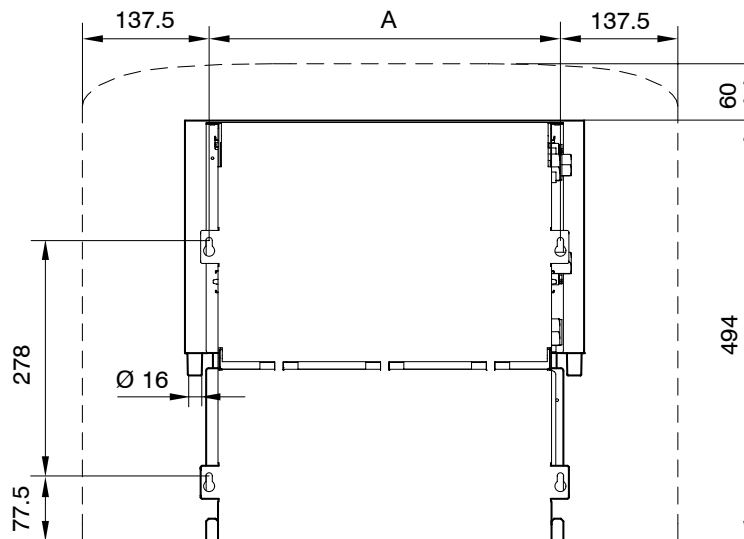

--- = Overall dimensions of casing
(if used)

MODEL	15	20	30	40	50	60	80	100	120
A (mm)	415	415	665	665	915	915	915	1165	1165

GENERAL SPECIFICATIONS

MAIN BANK WET CONNECTIONS

Fig.13

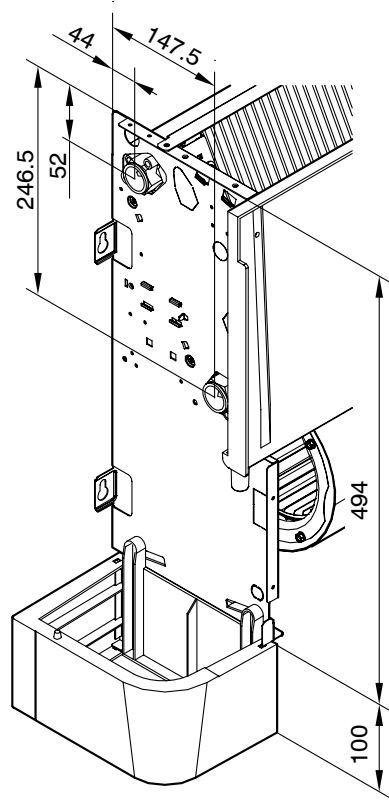

SUPPLEMENTARY BANK WET CONNECTIONS

Fig.14

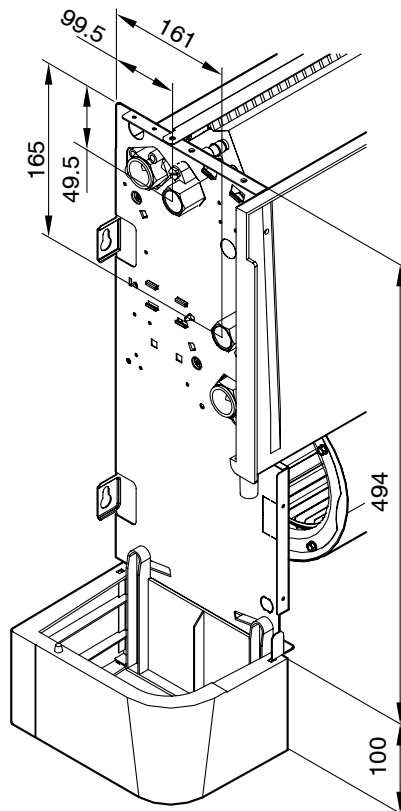

ACCESSORIES

TABLE OF ACCESSORY MATCHES

Tab.10

Description of accessories	Model	15	20	30	40	50	60	80	100	120	Versioni
Remote control switch	CMR-F	•	•	•	•	•	•	•	•	•	VM-B/VM-F/VN
Basic remote controlled thermostat	TAR-F	•	•	•	•	•	•	•	•	•	VM-B/VM-F/VN
Upgraded remote controlled thermostat	TER-F	•	•	•	•	•	•	•	•	•	VM-B/VM-F/VN
Cabinet switch	CM-F	•	•	•	•	•	•	•	•	•	VM-B/VM-F/VN
Basic cabinet thermostat	TA-F	•	•	•	•	•	•	•	•	•	VM-B/VM-F/VN
Upgraded cabinet thermostat	TE-F	•	•	•	•	•	•	•	•	•	VM-B/VM-F/VN
Bearing feet	PA-F	•	•	•	•	•	•	•	•	•	VM-B
Additional horizontal tray	BCO-F	•	•	•	•	•	•	•	•	•	VM-B/VM-F/VN
Additional vertical tray	BCV-F	•	•	•	•	•	•	•	•	•	VM-B/VM-F/VN
Suppl.bank 3-way On-Off valve	VB1-F	•	•	•	•	•	•	•	•	•	VM-B/VM-F/VN
3-way On-Off valve for bank	VB3-F	•	•	•	•	•	•	•	•	•	VM-B/VM-F/VN
Enabling thermostat	TC-F	•	•	•	•	•	•	•	•	•	VM-B/VM-F/VN
Supplementary bank	BS-F1	•	•								VM-B/VM-F/VN
	BS-F2			•	•						VM-B/VM-F/VN
	BS-F3					•	•	•			VM-B/VM-F/VN
	BS-F4								•	•	VM-B/VM-F/VN
Straight delivery flange	FMD-F1	•	•								VN
	FMD-F2			•	•						VN
	FMD-F3					•	•				VN
	FMD-F4								•	•	VN
Perpendicular delivery flange	FMP-F1	•	•								VN
	FMP-F2			•	•						VN
	FMP-F3					•	•	•			VN
	FMP-F4								•	•	VN
Delivery plenum	PM-F1	•	•								VN
	PM-F2			•	•						VN
	PM-F3					•	•	•			VN
	PM-F4								•	•	VN
Straight intake flange	FAD-F1	•	•								VN
	FAD-F2			•	•						VN
	FAD-F3					•	•	•			VN
	FAD-F4								•	•	VN
Perpendicular intake flange	FAP-F1	•	•								VN
	FAP-F2			•	•						VN
	FAP-F3					•	•	•			VN
	FAP-F4								•	•	VN
Delivery grille	GM-F1	•	•								VN
	GM-F2			•	•						VN
	GM-F3					•	•	•			VN
	GM-F4								•	•	VN
Intake grille	GA-F1	•	•								VN
	GA-F2			•	•						VN
	GA-F3					•	•	•			VN
	GA-F4								•	•	VN
Rear closing panel	PC-F1	•	•								VM-B/VM-F
	PC-F2			•	•						VM-B/VM-F
	PC-F3					•	•	•			VM-B/VM-F
	PC-F4								•	•	VM-B/VM-F
Electric heating elements	RE-F1	•	•								VM-B/VM-F/VN
	RE-F2			•	•						VM-B/VM-F/VN
	RE-F3					•	•	•			VM-B/VM-F/VN
	RE-F4								•	•	VM-B/VM-F/VN
Inlet plenum	PA-F1	•	•								VN
	PA-F2			•	•						VN
	PA-F3					•	•	•			VN
	PA-F4								•	•	VN
Outdoor air inlet	SR-F1	•	•								VM-B/VN
	SR-F2			•	•						VM-B/VN
	SR-F3					•	•	•			VM-B/VN
	SR-F4								•	•	VM-B/VN
Outdoor air inlet motor	MS-F	•	•	•	•	•	•	•	•	•	VM-B/VN
Positionable fin	AO-F1	•	•								VM-B/VM-F
	AO-F2			•	•						VM-B/VM-F
	AO-F3					•	•	•			VM-B/VM-F
	AO-F4								•	•	VM-B/VM-F
Condensation discharge pump	PSC-F	•	•	•	•	•	•	•	•	•	VM-B/VM-F/VN

ACCESSORIES

CONTROL PANEL

Two series of panels are available: for installation **on the machine** and for **remote controlled wall mounted installation**. Each of the series includes three types of control: **switch**, **basic thermostat** and **upgraded thermostat**.

FUNCTIONS

The various functions available are listed below to allow the type of control model to be selected more quickly. These functions are described in the following pages.

Tab.11

APPLICATION	Cabinet			Remote control		
	Switch	Basic thermostat	Upgraded thermostat	Switch	Basic thermostat	Upgraded thermostat
FUNCTIONS						
General control of the unit						
Main ON-OFF switch	•	•	•	•	•	•
Temperature control						
Thermostat controlled temperature		•	•		•	•
Set point variation by means of Economy button			•			•
ventilation control						
Manual selection of fan speed	•	•	•	•	•	•
Automatic selection of fan speed			•			•
SUM./WIN. seasonal mode control						
Manual SUM./WIN. mode selection on control		•	•		•	•
Autom. SUM./WIN. mode selection on control		•	•		•	•
Remote controlled SUM./WIN. mode selection			•			•
Management of Valves/Electric heating elements						
Main bank valve		•	•		•	•
Electric heating element/auxiliary bank valve			•			•
Functions configured during installation phase						
ON/OFF/Continuous thermostat fan control		•	•		•	•
Probe reading correction		•	•		•	•
Configuration of unit - System with 2 pipes			•			•
Configuration of unit - System with 4 pipes			•			•
Configuration of unit - System with 2 pipes+Heat.el.			•			•
Heating element control			•	•	•	•
Dead zone set-up			•			•
Integration with accessories						
Bimetallic minimum temperature probe	•			•		

ACCESSORIES

DESCRIPTION OF COMMUTATOR (CM-F/CMR-F)

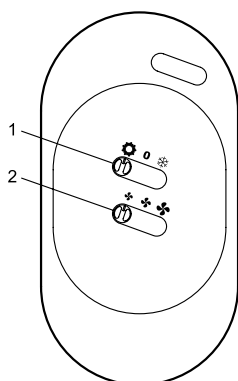

Fig.15

Commutator: cabinet (CM-F) and remote control (CMR-F)

1- when in position **0**, selector **1** indicates the off command. Turn to the **sun** symbol to select the heat mode or to the **snow** symbol to select the cool mode.

2- selector **2** is used to choose the minimum, medium or maximum fan speeds.

DESCRIPTION OF THE BASIC THERMOSTAT (TA-F/TAR-F)

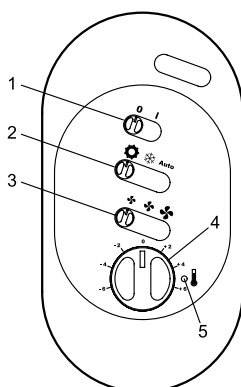

Fig.16

Basic thermostat: cabinet (TA-F) and remote control (TAR-F)

1- on/off cursor to turn the appliance on and off.

2- seasonal selector; turn to the **sun** symbol to select the heat mode or to the **snow** symbol to select the cool mode. Turn to **auto** and the control will select the operating mode on its own depending on the ambient temperature.

3- selector **3** is used to choose the minimum, medium or maximum fan speeds.

4- use knob **4** to set the required temperature. The temperature setting that corresponds to position **0** is **20°C in heat mode** and **25°C in in the cool mode**.

5- the **red led** is on when the thermostat function of the control is operating.

DESCRIPTION OF UPGRADED THERMOSTAT (TE-F/TER-F)

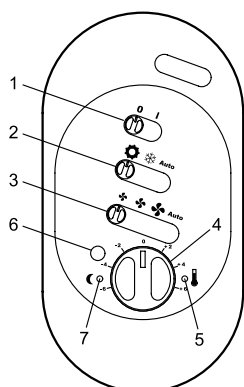

Fig.17

Upgraded thermostat: cabinet (TE-F) and remote control (TER-F)

1- on/off cursor to turn the appliance on and off.

2- seasonal selector; turn to the **sun** symbol to select the heat mode or to the **snow** symbol to select the cool mode. Turn to **auto** and the control will select the operating mode on its own depending on the ambient temperature.

3- selector **3** is used to choose the minimum, medium or maximum fan speeds. In automatic mode, the control selects the adequate speed on its own.

4- use knob **4** to set the required temperature. The temperature setting that corresponds to position **0** is **20°C in heat mode** and **25°C in in the cool mode**.

5- the **red led** is on when the thermostat function of the control is operating.

6- the **economy** key can be used to change the winter and summer set points. When the key is pressed, the **green led (7)** will come on and ventilation will be forced to minimum speed. The previously **set-point** is changed by **-3°C** in heat mode and by **+3°C** in cold mode thus obtaining, for example, **17°C** in heat mode and **28°C** in cool mode in relation to the 0 position.

ACCESSORIES

OVERALL DIMENSIONS OF CONTROL PANEL

Fig.18

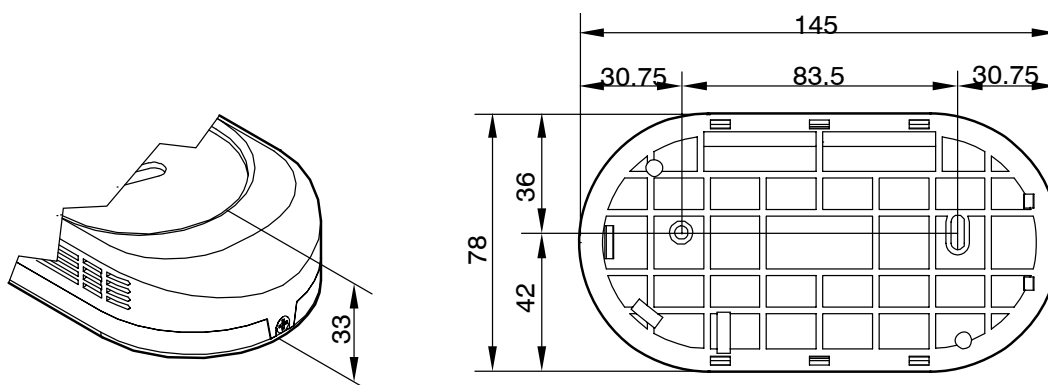

TECHNICAL SPECIFICATIONS

Tab.18

ELECTRICAL SPECIFICATIONS	WALL-MOUNTED VERSION	VERSION ON MACHINE
Power source voltage rating	230V \pm 10%	230V \pm 10%
Power source frequency	50Hz	50Hz
Maximum power draw	-	-
Protection degree	Lower than IP40	Lower than IP40
Operating ambient temperature	0 to 50°C	0 to 50°C
Non-condensing room humidity	10 to 90%	10 to 90%
Storage temperature	-20 to 85°C	-20 to 85°C
Non-condensing storage humidity	10 to 90%	10 to 90%
Max. current of valve and/or heating element relay control output terminals	0.5A	0.5A
Max. current of fan output terminals	1A	1A
PROBES		
Air probe NTC 10k-25°C - precision: err<1°C between +5°C and 50°C	Mounted on board	Mounted on air intake - length = 600 mm
Air probe NTC 10k-25°C - precision: err<1°C between +5°C and 50°C	Mounted in contact with water bank - length 1800mm	Mounted in contact with water bank - length 1800mm

ACCESSORIES

1: INSTALLATION OPTIONS

When the appliance is installed, the **basic** and **upgraded** controls can be configured in the following way:

• **How to configure the type of machine:**

Carried out by means of dip switches, this operation allows the type of control application to be selected.

TYPE OF APPLICATION	Basic thermostat	Upgraded thermostat
Machine with 4 pipes		•
Machine with 2 pipes without heating elements	•	•
Machine with 2 pipes with heat. el. in substitution		•
Machine with 2 pipes with integrated heat.elements		•
Valve thermostat action	•	•
Fan thermostat action	•	•
Dead zone 1 (2°C)	•	•
Dead zone 2 (5°C)	•	•
Remote controlled summer/winter funct.activation		•

• **Air probe compensation**

Available in both the basic and upgraded model, this operation allows the air probe reading to be calibrated by means of 4 jumpers in order to correct any errors. The function is activated in **HEAT** and **COOL** mode.

• **Summer/winter remote control**

Available in the **upgraded thermostat** version only where there is a digital input in the terminal board to handle the **SUMMER/WINTER** remote control. The digital input is the clean type and is therefore handled by means of a contact that can only operate in two statuses: **OPEN= summer**, **CLOSED= winter**.

Attention: take the utmost care when wiring the **summer/winter** remote control since the terminals are live even though the digital input is clean (if does not required voltage to activate the function).

The configuration mode details are described in the instructions enclosed with the control unit.

2: OPERATING MODES

There are 3 types of operation:

- cooling and heating function for the basic and upgraded control with thermostat monitoring action on the valve/s.
- cooling and heating function for the basic and upgraded control with thermostat monitoring on the fan.
- heating function with integrated or alternative heating elements for the upgraded control.

The installation instructions of the control describe how to select the operating modes.

ACCESSORIES

2.1: FAN THERMOSTAT ACTION

In this case, the valve is not used (hot or cold water flows freely into the bank) and thermoregulation occurs by turning the fan on or off. This regulation is associated with both the **heat** and **cool** modes. To prevent the ambient probe from making reading errors, the **PERIODIC VENTILATION** function is activated in both the cool and heat modes.

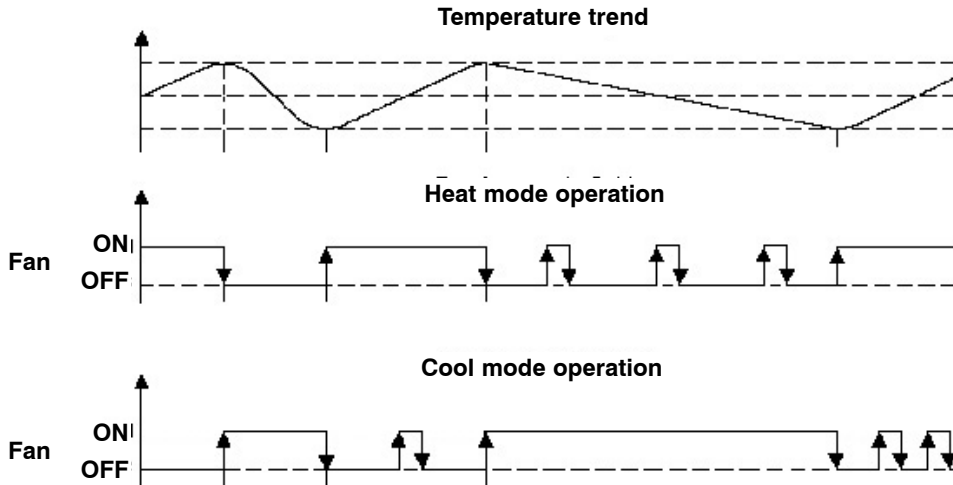

Graph showing the fan **heating/cooling** thermostat action

2.2: VALVE THERMOSTAT ACTION

In this case, fan management differs depending on whether the appliance operates in **heat** or **cool** mode, as described below:

- **Cool mode:** the thermostat function opens/closes the valve as required, while the fan is permanently on even when the thermostat action has been accomplished.
- **Heat mode:** the thermostat function opens/closes the valve while the fan is managed with delay times linked to the **HOT START** and **PERIODIC VENTILATION** functions (described on page 35).

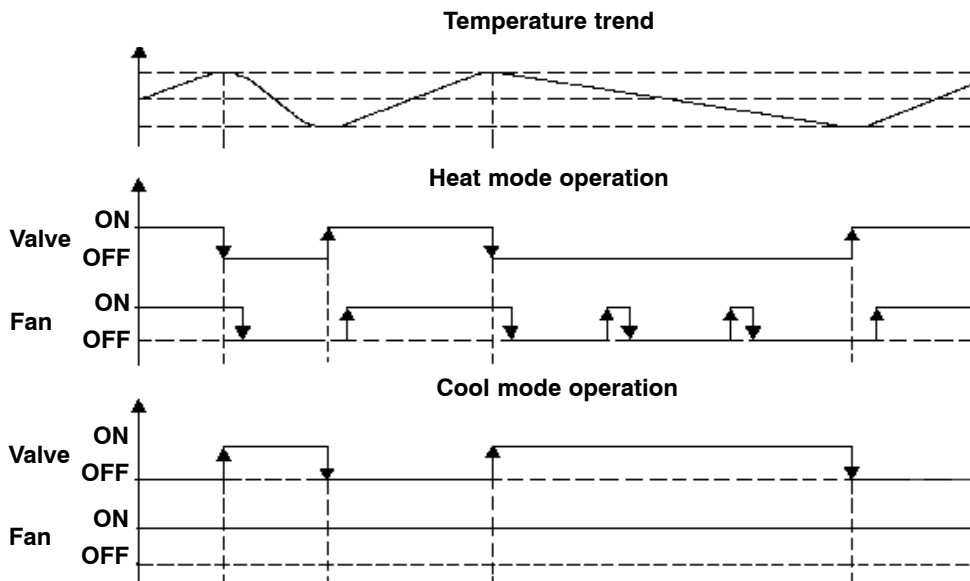

Graph of valve **heating/cooling** thermostat action

ACCESSORIES

Valve management includes an **ON/OFF** control with valve shut signal when the set-point has been reached according to the hysteresis cycles of the **heating/cooling** graphs. The valves required are the normally closed type with endothermic actuators and opening/closing times of approx. **3 minutes**.

The fan is managed with the time settings described in the **VENTILATION CONTROL** section in order to keep the ambient temperature constantly monitored.

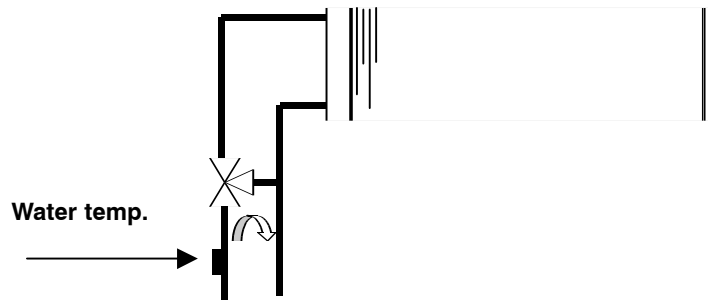

Position of the water probe

THERMOSTAT MODE HYSTERESIS:

The hysteresis value is **1°C** for the controls on the machine and **0.6°C** for the wall-mounted controls.

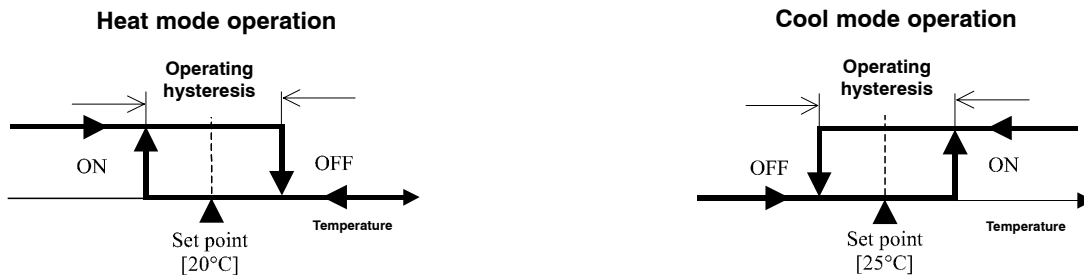

2.3: ELECTRIC HEATING ELEMENTS

Electric heating elements can only be used with the upgraded thermostat in the configuration with 2 pipes. The electric heating elements can operate either **in substitution** or as **an integration**:

- **HEATING ELEMENTS IN SUBSTITUTION:** Heating is only obtained with the heating elements. In this case, the output of the 2nd valve is now used to pilot a bank of electric heating elements using a suitable relay. After the heating elements have been turned off, there is a post-ventilation phase lasting 90 seconds to allow them to cool down.

- **INTEGRATED HEATING ELEMENTS:** The heating element and the valve operate together. Heating occurs with: **the heating elements** if the H₂O temperature is less than **34°C**; with the water, if the temperature is **34.5°C** or more, with a central hysteresis of **1°C (±0.5°C)** in relation to the **34°C**.

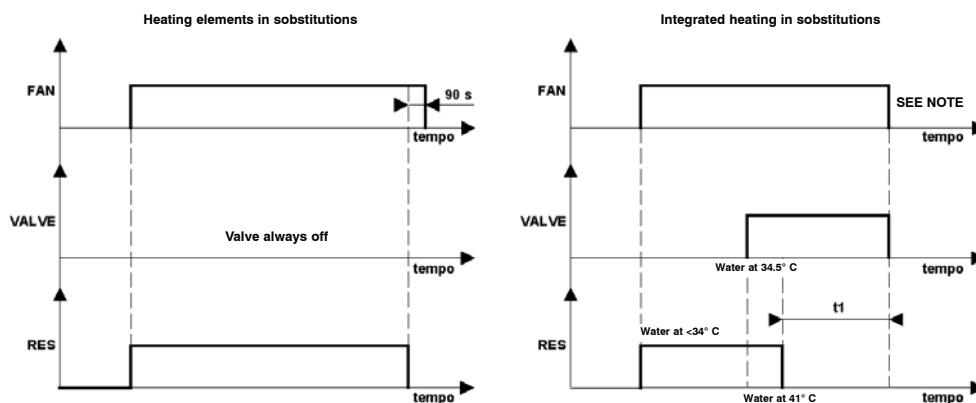

Heating regulation with electric heating elements

ACCESSORIES

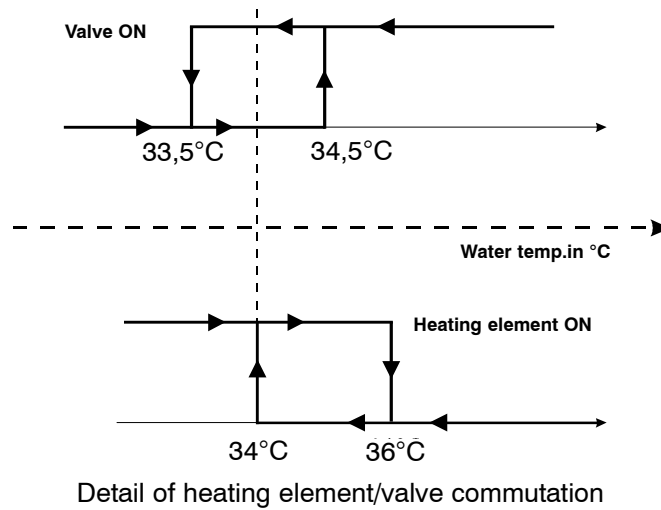

Notes:

- If the thermoregulator transfers **HEAT** management from the electric heating elements to the water valve, delayed ventilation activation of **180 seconds** will not occur and the fan will be permanently activated (since the air is kept warm by the heating elements until the valve opens).
- In integration mode, the heating elements will be de-activated when the water reaches a temperature of **>36°C**.

ACCESSORIES

3: VENTILATION CONTROL

Fan management with the **basic** and **upgraded** thermostats depends on the selected operating mode (**cool, heat, heating elements**):

- Fan speed:

If the fans are activated, their speed may be:

- Manually selected by the user;
- Automatically selected if the fan switch is set to auto mode (**upgraded thermostat only**).

- Fan thermostat action:

The fan will activate and de-activate as described on page 31.

- Valve thermostat action:

If the valve thermostat action is enabled, the fan will be automatically set for continuous operation in **cool** mode (fans permanently on), while in **heat** mode, the fan is timed as the probe installed prior to the valve is no longer able to control the cold air inlet :

- Fan **ON** 180 seconds after the valve opening command;
- Fan **OFF** 180 seconds after valve closing command.

The **hot start** function is always activated (in heat mode) for water temperatures of below **34°C**

Automatic ventilation:

Automatic fan operation starts at forced minimum speed for 60 sec., after which it is regulated according to the difference between ambient temperature and the temperature value set by means of the **set-points**.

This difference depends on the hysteresis set in the regulator, which is:

- **0.6°C** for wall-mounted control units;
- **1°C** for controls units mounted on the machine.

The figure below gives the difference values of control units mounted on the machine. The difference values should be replaced in the following way to adapt the graphs to the wall-mounted model:

- **Cool mode:** values +1, +2, +3, become +0.6, +1.2, +1.8;

- **Heat mode:** values -1, -2, -3, become -0.6, -1.2, -1.8.

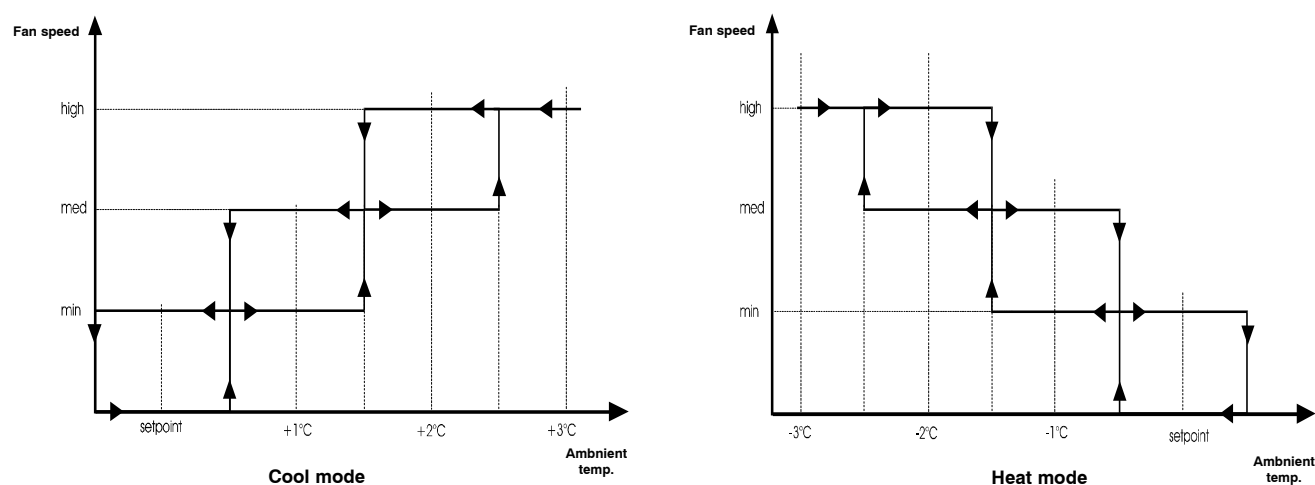

Graph showing automatic fan management for thermostats on the machine (1°C hysteresis)

Note: the set-point shown in the x-axis of the graphs refers to the value set by the user on the potentiometer.

ACCESSORIES

3.1: PERIODIC VENTILATION

If the control is installed on the machine and the fan is off because the thermostat function has been complied with, there are fan **ON/OFF** cycles to allow the air probe to detect the effective temperature in the environment. This function is activated in both **heat** and **cool** mode.

HOT- START function:

The heat exchanger is pre-heated before the fan is activated. This function is only enabled in **heat** mode and takes place in the two steps described below.

- **Ventilation delay:** For control units with the valve thermostat action: there is a 180 second fixed delay between activation of the heat governor and activation of the ventilating action to allow the valve to fully open. After 180 seconds, the ventilating action will still only start when the water probe detects a temperature of **34.5°C** or more. This function is not available in control units with the fan thermostat action.

- **Ventilation enabling:** The ventilating action will only start if the temperature of the water exceeds **34.5°C**. This function is available in both control units with the valve thermostat action and in ones with the fan thermostat action. Hysteresis graph of the thermostat action (valve or fan, depending on the type of control unit).

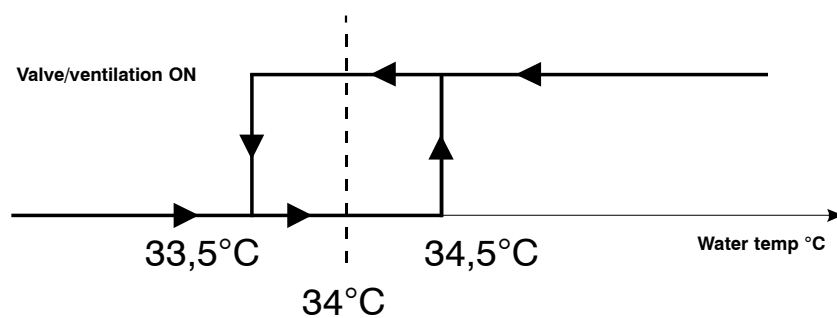

Graph showing the hysteresis of the thermostat action

3.2: POST-VENTILATION

After the electric heating elements have been de-activated by the thermostat function, the ventilating action will continue for a further 90 seconds.

ACCESSORIES

OVERALL DIMENSIONS OF BEARING FEET (PA-F)

Entirely made of **anti-UV** plastic material, the feet are fitted to the base of cabinets which intake from below when these are installed on the floor.

Fig.19

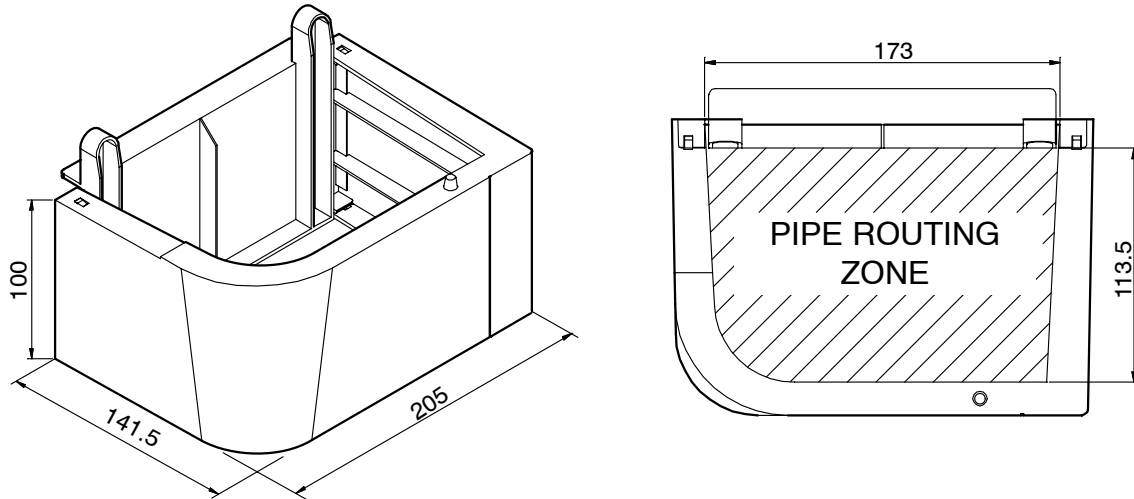

OVERALL DIMENSIONS OF TRAY (BCO-F/BCV-F)

This is made of plastic material. It collects the condensation that forms on the non-insulated wet connections and valve kits (if installed) during summer mode operation and conveys it outside. This accessory is supplied for both horizontally and vertically installed appliances.

Fig.20

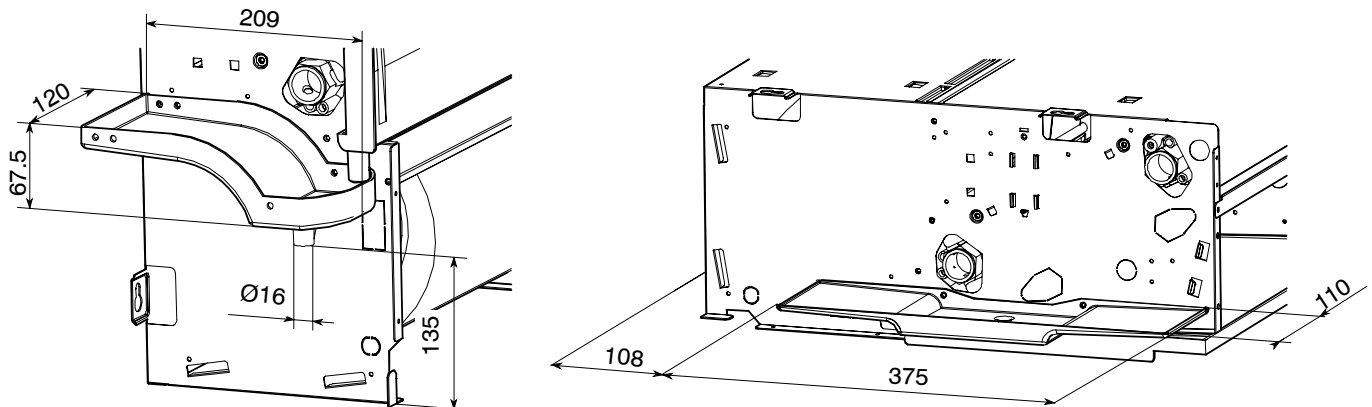

ACCESSORIES

THREE-WAY VALVE KIT FOR TRIPLE RANK BANK VB3-F

Kit complete with copper fittings and three-way valves of the **ON/OFF**, pre-engineered for a **230V** power source.

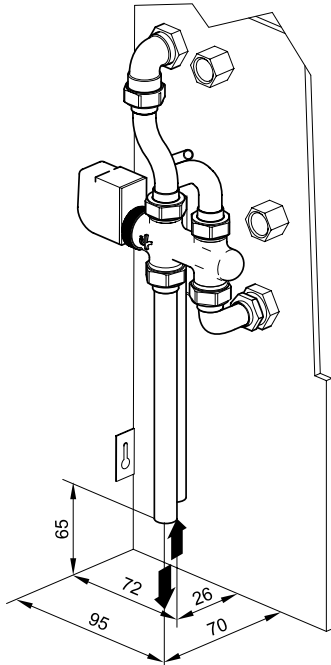
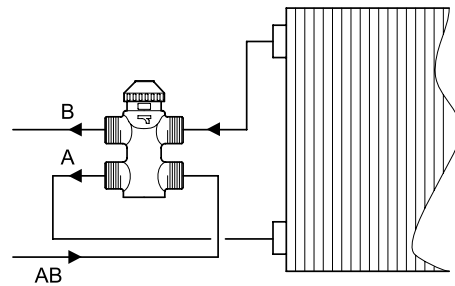

Fig.21



TECHNICAL SPECIFICATIONS

Initial power draw	W	8
Power draw when operating	W	5
Water temperature	°C	4-110
Opening time	sec.	120
Closing time	sec.	180
Maximum static pressure	kPa	1600
Ambient temperature	°C	0-40
Pipe Ø	mm	18
Protection degree		IP 44
Flow switching		
Valve supplied		AB - A
Valve not supplied		AB - B

Tab.19

KIT VB3-F VALVE LOAD LOSSES

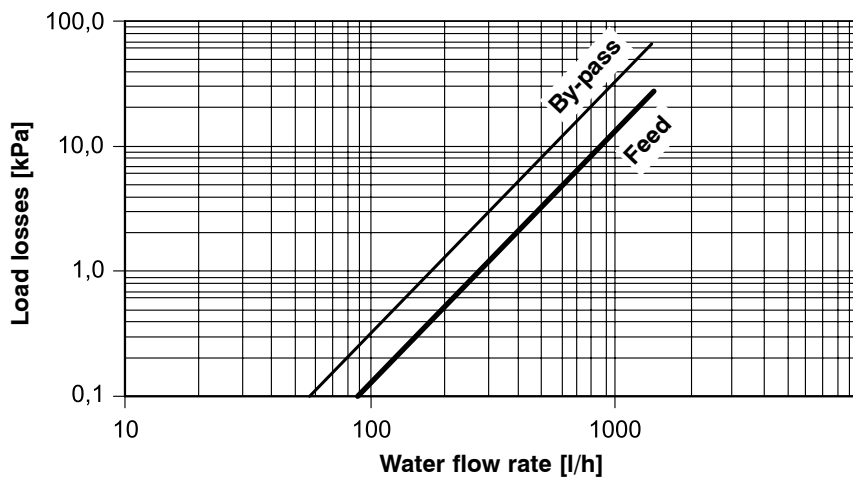

Graph 14

ACCESSORIES

THREE-WAY VALVE KIT FOR ONE RANK BANK VB1-F

Kit complete with copper fittings and three-way valves of the ON/OFF, pre-engineered for a 230V power source.

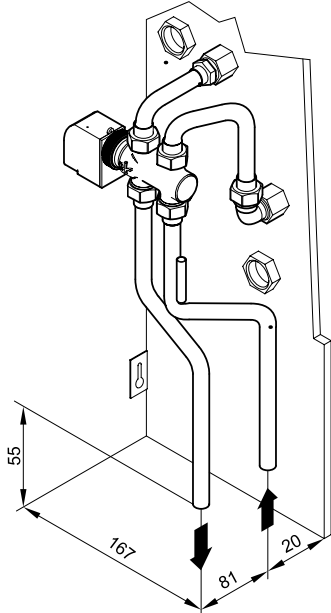
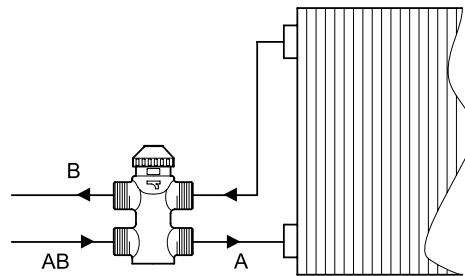

Fig.22



TECHNICAL SPECIFICATIONS

Initial power draw	W	8
Power draw when operating	W	5
Water temperature	°C	4-110
Opening time	sec.	120
Closing time	sec.	180
Maximum static pressure	kPa	1600
Ambient temperature	°C	0-40
Pipe Ø	mm	14
Protection degree		IP 44
Flow switching		
Valve supplied		AB - A
valve not supplied		AB - B

Tab.20

KIT VB1-F VALVE LOAD LOSSES

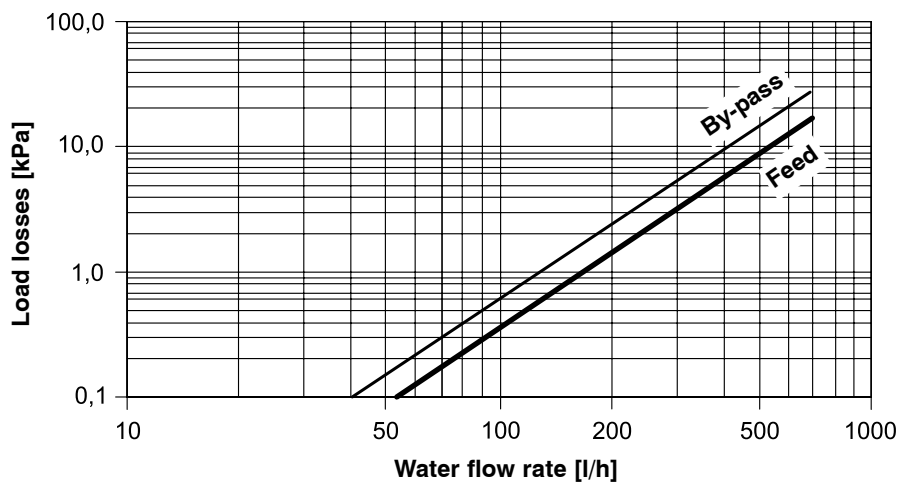

Graph 15

ACCESSORIES

ENABLING THERMOSTAT (TC-F)

This accessory can be used with the commutator-command to inhibit fan operation in heating mode if the temperature of the bank fails to reach an acceptable operating value.

Fig.23

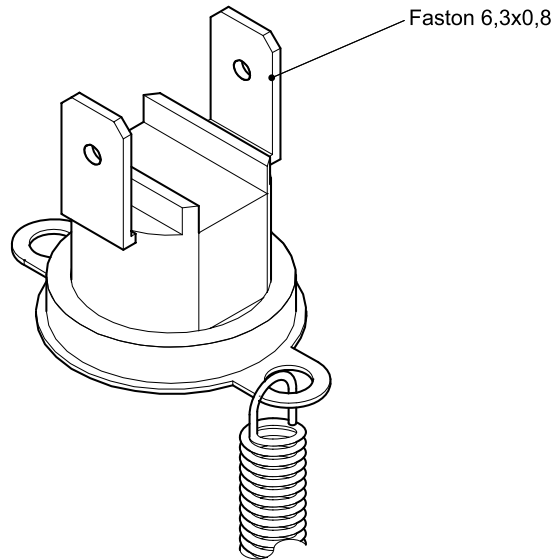

SUPPLEMENTARY BANK (BS-F)

Auxiliary heat exchanger fed with hot water for systems with four pipes. It is regulated by means of the upgraded thermostat accessory.

Fig.24

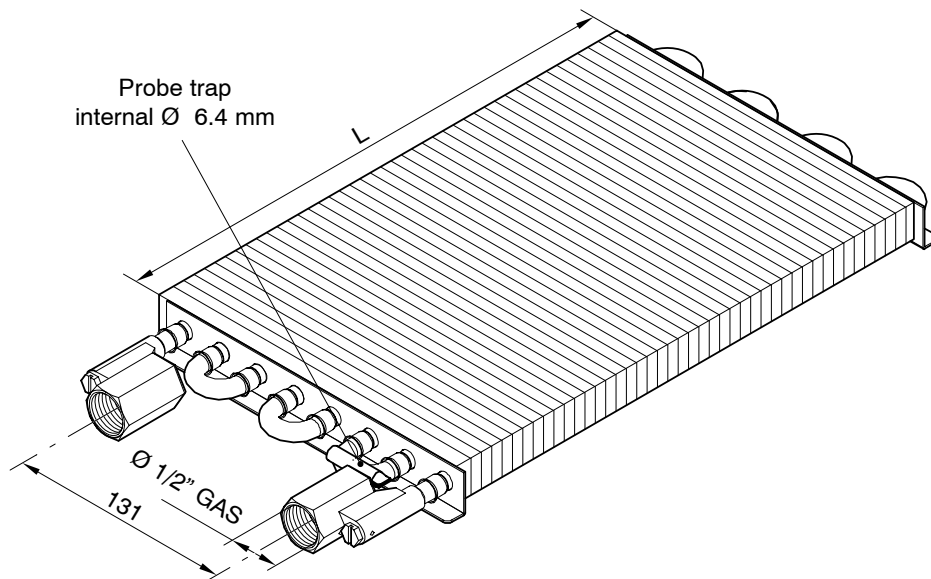

UNIT MODEL	15	20	30	40	50	60	80	100	120
Accessory Model	BS-F1	BS-F1	BS-F2	BS-F2	BS-F3	BS-F3	BS-F3	BS-F4	BS-F4
L (mm)	308	308	558	558	808	808	808	1058	1058

ACCESSORIES

OVERALL DIMENSIONS OF STRAIGHT DELIVERY FLANGE (FMD-F)

Made of galvanized sheet metal, this is used to convey the air in vertical or horizontal built-in installations.

Fig.25

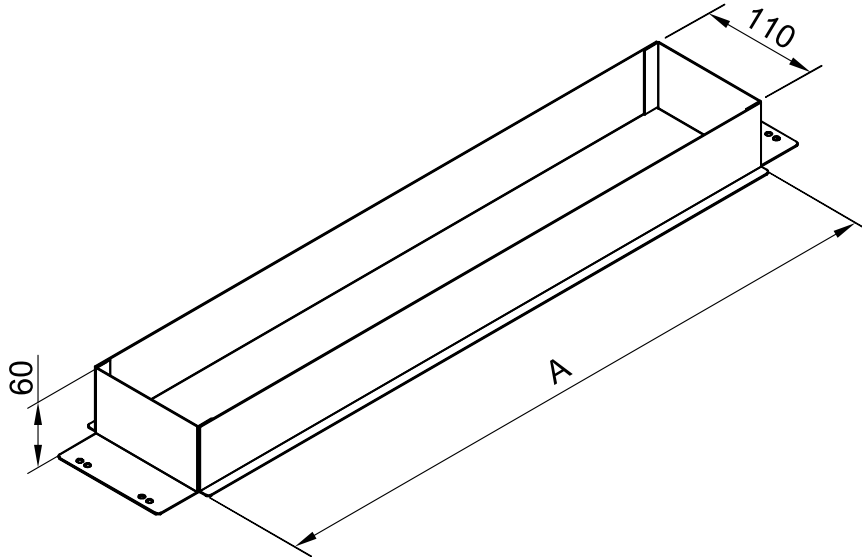

UNIT MODEL	15	20	30	40	50	60	80	100	120
Accessory Model	FMD-F1	FMD-F1	FMD-F2	FMD-F2	FMD-F3	FMD-F3	FMD-F3	FMD-F4	FMD-F4
A (mm)	390	390	590	590	790	790	790	990	990

OVERALL DIMENSIONS OF PERPENDICULAR DELIVERY FLANGE (FMP-F)

This is made of galvanized sheet metal and is used to convey the air in vertical or horizontal built-in installations.

Fig.26

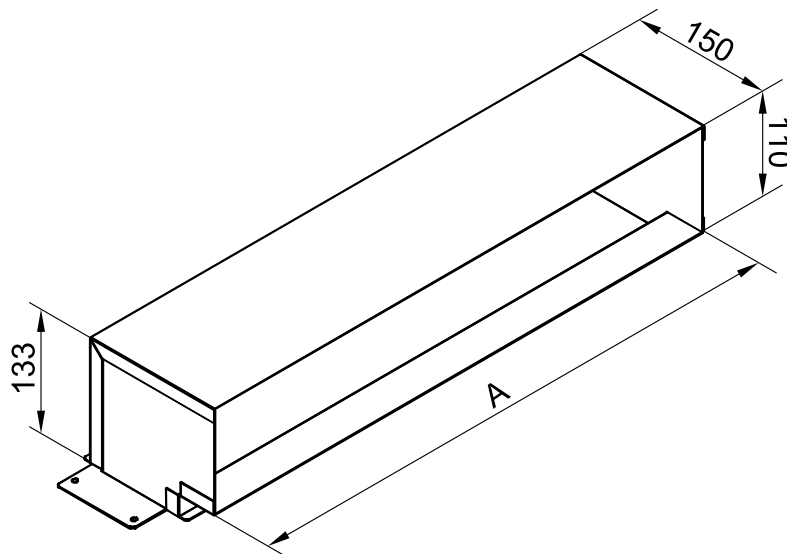

UNIT MODEL	15	20	30	40	50	60	80	100	120
Accessory Model	FMP-F1	FMP-F1	FMP-F2	FMP-F2	FMP-F3	FMP-F3	FMP-F3	FMP-F4	FMP-F4
A (mm)	392	392	592	592	792	792	792	992	992

ACCESSORIES

OVERALL DIMENSIONS OF DELIVERY PLENUM (PM-F)

Made of galvanized sheet metal and insulated on the inside to prevent heat bridges, meanwhile reducing the noise level produced. It is equipped with plastic flanges to join circular section channels.

Fig.27

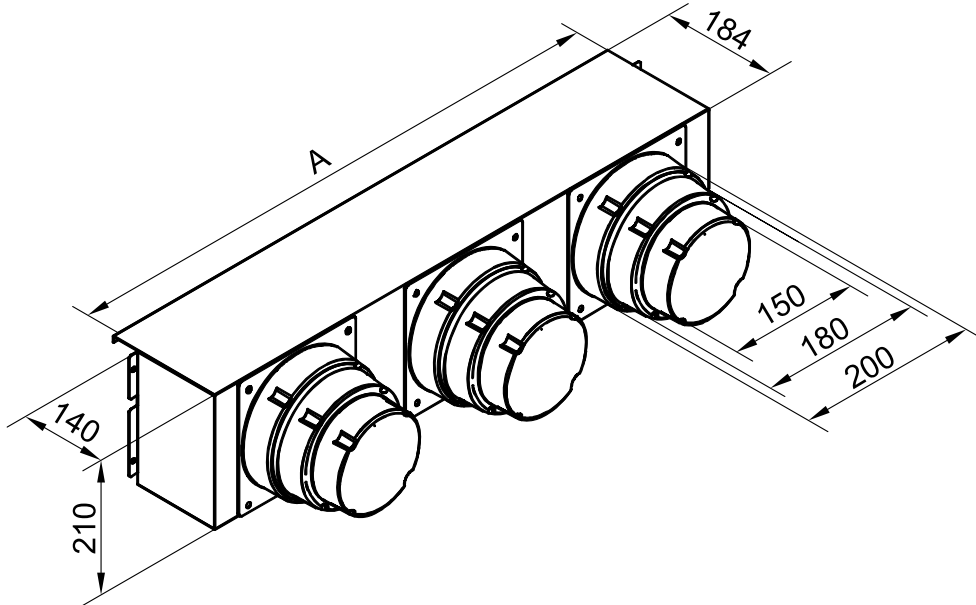

UNIT MODEL	15	20	30	40	50	60	80	100	120
Accessory Model	PM-F1	PM-F1	PM-F2	PM-F2	PM-F3	PM-F3	PM-F3	PM-F4	PM-F4
A (mm)	392	392	642	642	892	892	892	1142	1142
N° circular flanges	1	1	2	2	3	3	3	4	4

OVERALL DIMENSIONS OF STRAIGHT INTAKE FLANGE (PAD-F)

Made of galvanized sheet metal, this is used to convey the air in vertical or horizontal built-in installations.

Fig.28

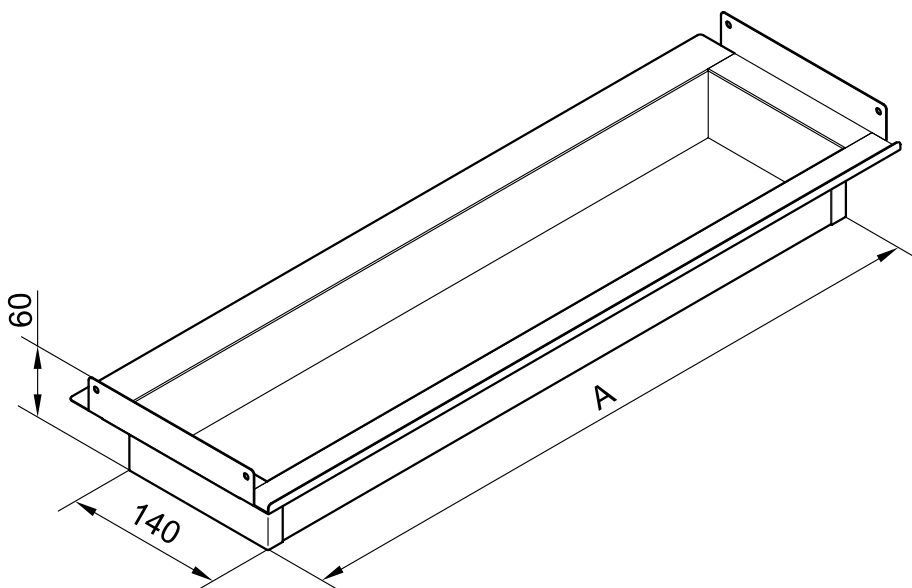

UNIT MODEL	15	20	30	40	50	60	80	100	120
Accessory Model	PAD-F1	PAD-F1	PAD-F2	PAD-F2	PAD-F3	PAD-F3	PAD-F3	PAD-F4	PAD-F4
A (mm)	390	390	590	590	790	790	790	990	990

ACCESSORIES

OVERALL DIMENSIONS OF PERPENDICULAR INTAKE FLANGE (FAP-F)

Made of galvanized sheet metal, this is used to convey the air in vertical or horizontal built-in installations.

Fig.29

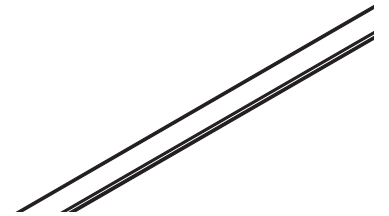

UNIT MODEL	15	20	30	40	50	60	80	100	120
Accessory Model	FAP-F1	FAP-F1	FAP-F2	FAP-F2	FAP-F3	FAP-F3	FAP-F3	FAP-F4	FAP-F4
A (mm)	392	392	592	592	792	792	792	992	992

OVERALL DIMENSIONS OF DELIVERY GRILLE (GM-F)

This is made of anodized aluminium and is complete with positionable vertical and horizontal fins.

Fig.30

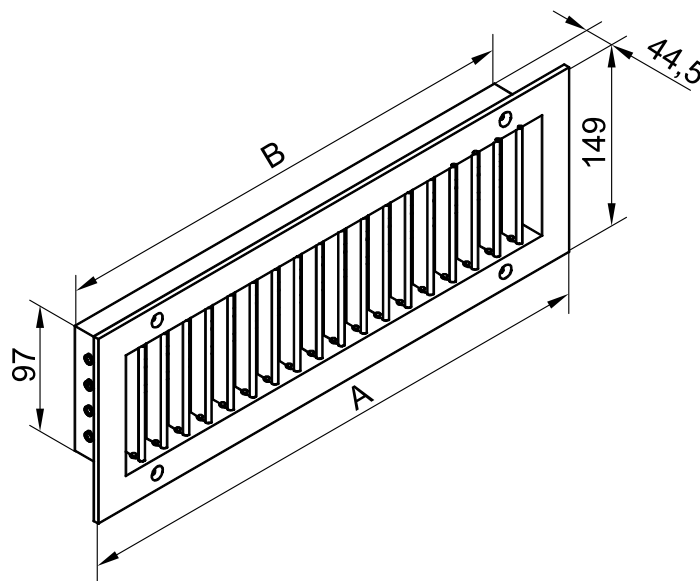

UNIT MODEL	15	20	30	40	50	60	80	100	120
Accessory Model	GM-F1	GM-F1	GM-F2	GM-F2	GM-F3	GM-F3	GM-F3	GM-F4	GM-F4
A (mm)	424	424	624	624	824	824	824	1024	1024
B (mm)	378	378	578	578	778	778	778	978	978

ACCESSORIES

OVERALL DIMENSIONS OF INTAKE GRILLE (GA-F)

This is made of anodized aluminium and has a filter that can be easily removed.

Fig.31

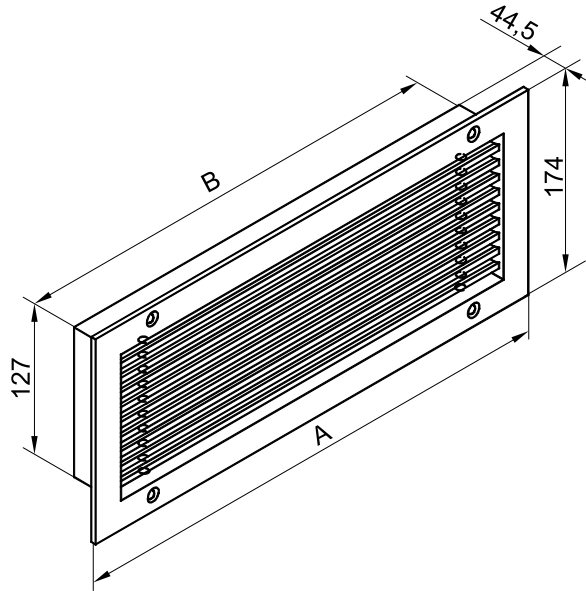

UNIT MODEL	15	20	30	40	50	60	80	100	120
Accessory Model	GA-F1	GA-F1	GA-F2	GA-F2	GA-F3	GA-F3	GA-F3	GA-F4	GA-F4
A (mm)	424	424	624	624	824	824	824	1024	1024
B (mm)	378	378	578	578	778	778	778	978	978

OVERALL DIMENSIONS OF REAR CLOSING PANEL (PC-F)

This is made of painted sheet metal and can be used to close the rear part of the convector fan if visible. It is obligatory to mount this accessory if the appliance is installed away from the wall to prevent access to live parts, as established by the reference standards in merit.

Fig.32

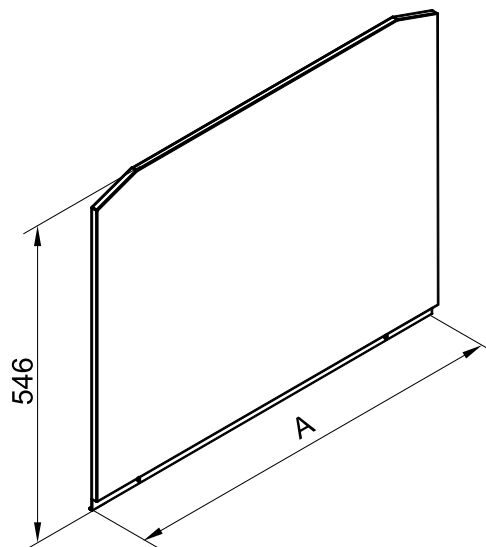

UNIT MODEL	15	20	30	40	50	60	80	100	120
Accessory Model	PC-F1	PC-F1	PC-F2	PC-F2	PC-F3	PC-F3	PC-F3	PC-F4	PC-F4
A (mm)	671	671	921	921	1171	1171	1171	1421	1421
B (mm)	546	546	546	546	546	546	546	546	546

ACCESSORIES

ELECTRIC HEATING ELEMENT SPECIFICATIONS (RE-F)

Kit with electric heating elements of the finned type in aluminium complete with double thermostat with automatic reset and manual resetting safety device.

Operating temperature T1= **120°C**
 Operating temperature T2= **200°C**

Fig.33

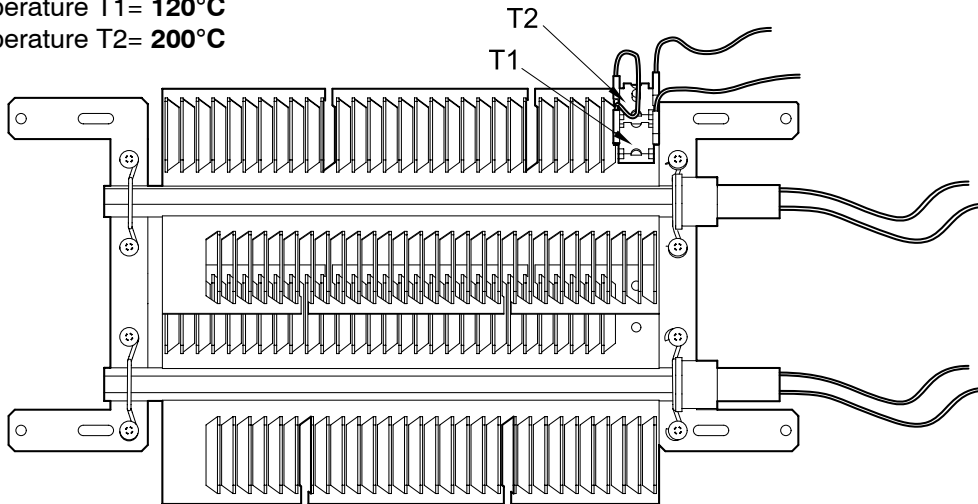

UNIT MODEL	15	20	30	40	50	60	80	100	120
Accessory Model	RE-F1	RE-F1	RE-F2	RE-F2	RE-F3	RE-F3	RE-F3	RE-F4	RE-F4
El. power rating	800	800	1500	1500	2200	2200	2200	2600	2600
Power draw (A)	3.5	3.5	6.5	6.5	9.6	9.6	9.6	11.3	11.3
Voltage rating (V)	230 V	230 V	230 V	230 V	230 V	230 V	230 V	230 V	230 V

DIMENSIONS OUTDOOR AIR INLET (SR-F)

Made of galvanized steel plate with manual control as standard supply. Allows the air in the room to be changed by opening the convector fan intake on to the outside environment.

Fig.34

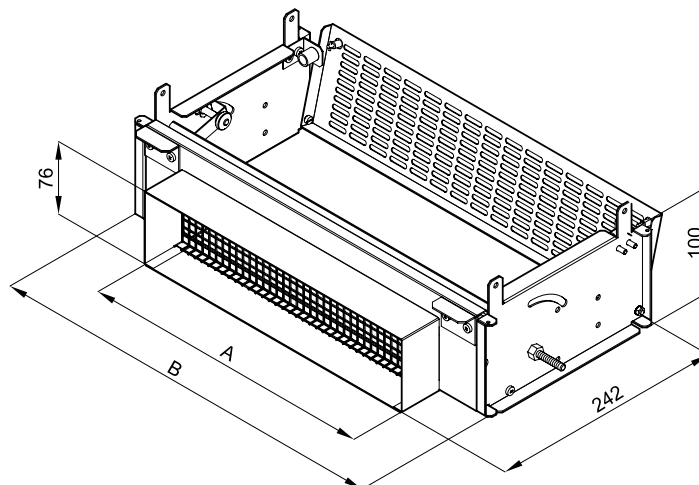

UNIT MODEL	15	20	30	40	50	60	80	100	120
Accessory Model	SR-F1	SR-F1	SR-F2	SR-F2	SR-F3	SR-F3	SR-F3	SR-F4	SR-F4
A (mm)	306	306	556	556	806	806	806	1056	1056
B (mm)	414	414	664	664	914	914	914	1164	1164

ACCESSORIES

OUTDOOR AIR INLET MOTOR (MS-F)

The servomotor is used to operate the outdoor air inlet (SR-F).
Powered with a 230V rating, it allows the inlet to be turned On and Off.

Fig.35

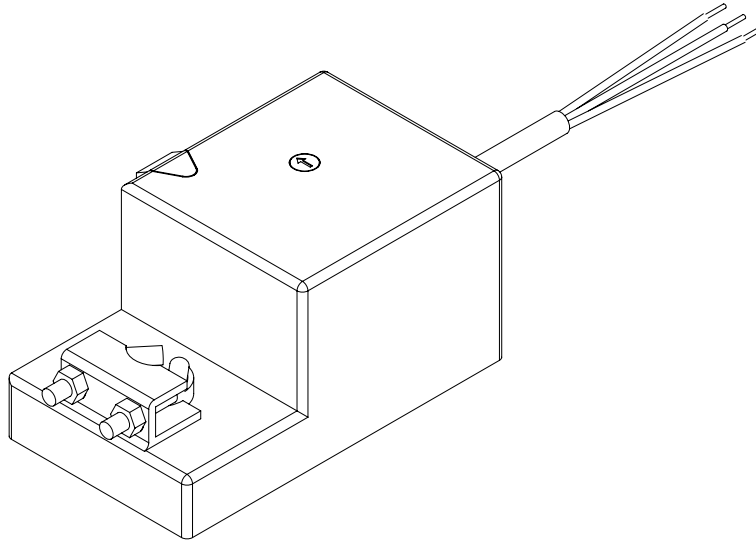

OVERALL DIMENSIONS OF INLET PLENUM (PA-F)

The inlet fan plenum, made of galvanized plate is used to direct air into vertical and horizontal recessed installations.

This accessory has plastic flanges for coupling ducts with a circular cross-section.

Fig.27

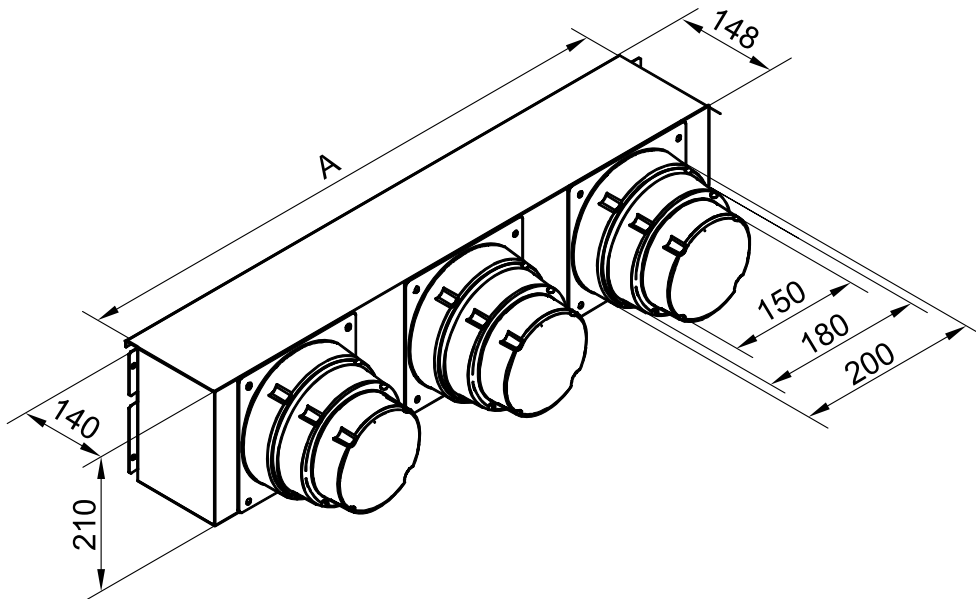

UNIT MODEL	15	20	30	40	50	60	80	100	120
Accessory Model	PA-F1	PA-F1	PA-F2	PA-F2	PA-F3	PA-F3	PA-F3	PA-F4	PA-F4
A(mm)	362	362	612	612	862	862	862	1112	1112
N° circular flanges	1	1	2	2	3	3	3	4	4

ACCESSORIES

POSITIONABLE FIN KIT (AO-F)

The positionable fin kit, entirely made of anti UV ABS material, is fitted to encased convector fans in the VM-B and VM-F versions to deviate the delivery air flow sideways.

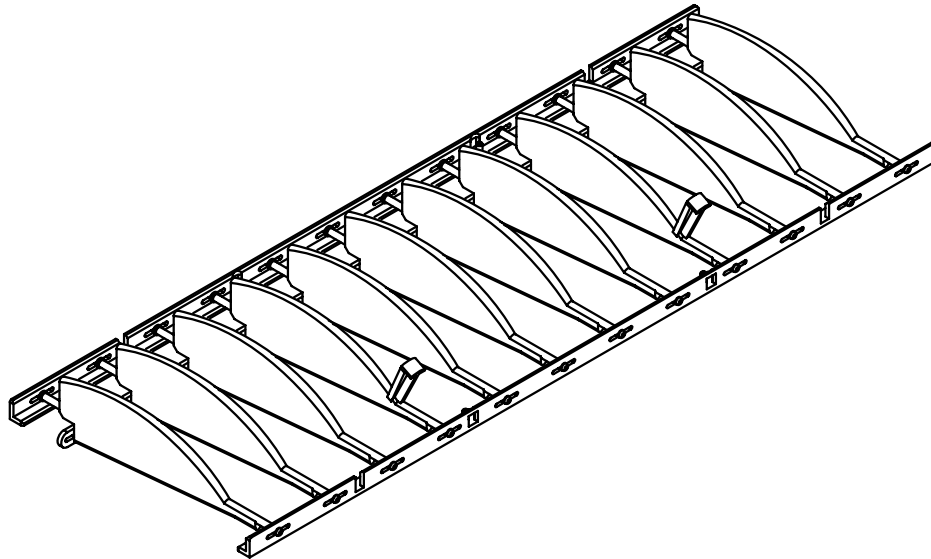

Fig.37

CONDENSATION DISCHARGE PUMP KIT (PSC-F)

The condensation discharge pump kit is installed to drain the condensation from the tray when the drain pipe cannot be slanted in an adequate way.

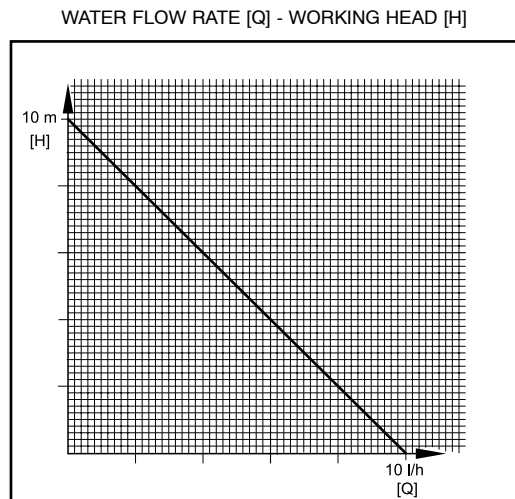
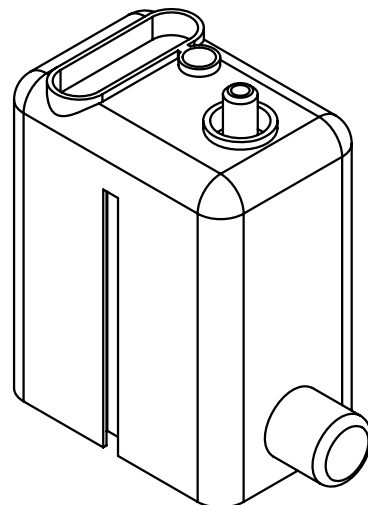

Fig.38



TECHNICAL SPECIFICATIONS		
Power supply	V-f-Hz	230-1-50
Total power input	W	12
Acoustic pressure	dB(A)	<31

ELECTRICAL CONNECTIONS

KEY TO WIRING DIAGRAMS

MT	= Ground terminal
MO	= Main terminal board
CN1	= Motor connector
CN	= Control connector
REM	= Remote control for function changes (with 230V voltage rating)
EC	= Economy function key
MA	= Brown wire
GR	= Grey wire
G/V	= Yellow/green wire
MRS	= Red wire (3rd speed-min.)
MBL	= Blue wire (2nd speed-med.)
MNE	= Black wire (1st speed-max.)
MBI	= White wire (common connection)
VE	= Green wire
GI	= Yellow wire
TC	= Enabling thermostat (opt.)
ST	= Seasonal selector
SV	= Fan speed selector
MV	= Fan motor
CV	= Fan condenser
SB	= Bank probe
SA	= Ambient probe
L-EC	= Economy Led
L-ON/OFF	= ON/OFF Led
IG	= Switch at user's charge with breaking capacity of not less than 4.5 kA
CO	= Terminal battery
K1	= Valve/heating element accessory command
TS	= Set point variator
VM	= ON/OFF valve accessory command (opt.)
ON/OFF	= ON/OFF selector

- The dotted lines represent connections at the installer's charge; wire type **H05 VV-K** 1.5 mm² or depending on installation. Consult the specific standards.

NOTE: Eliminate the jumper between terminals 4-5 in order to install the TC

ELECTRICAL CONNECTIONS

WIRING DIAGRAMS

COMMUTATOR wiring diagram

SPEED SELECTOR AND HEAT/COOL FUNCTION CONTROL

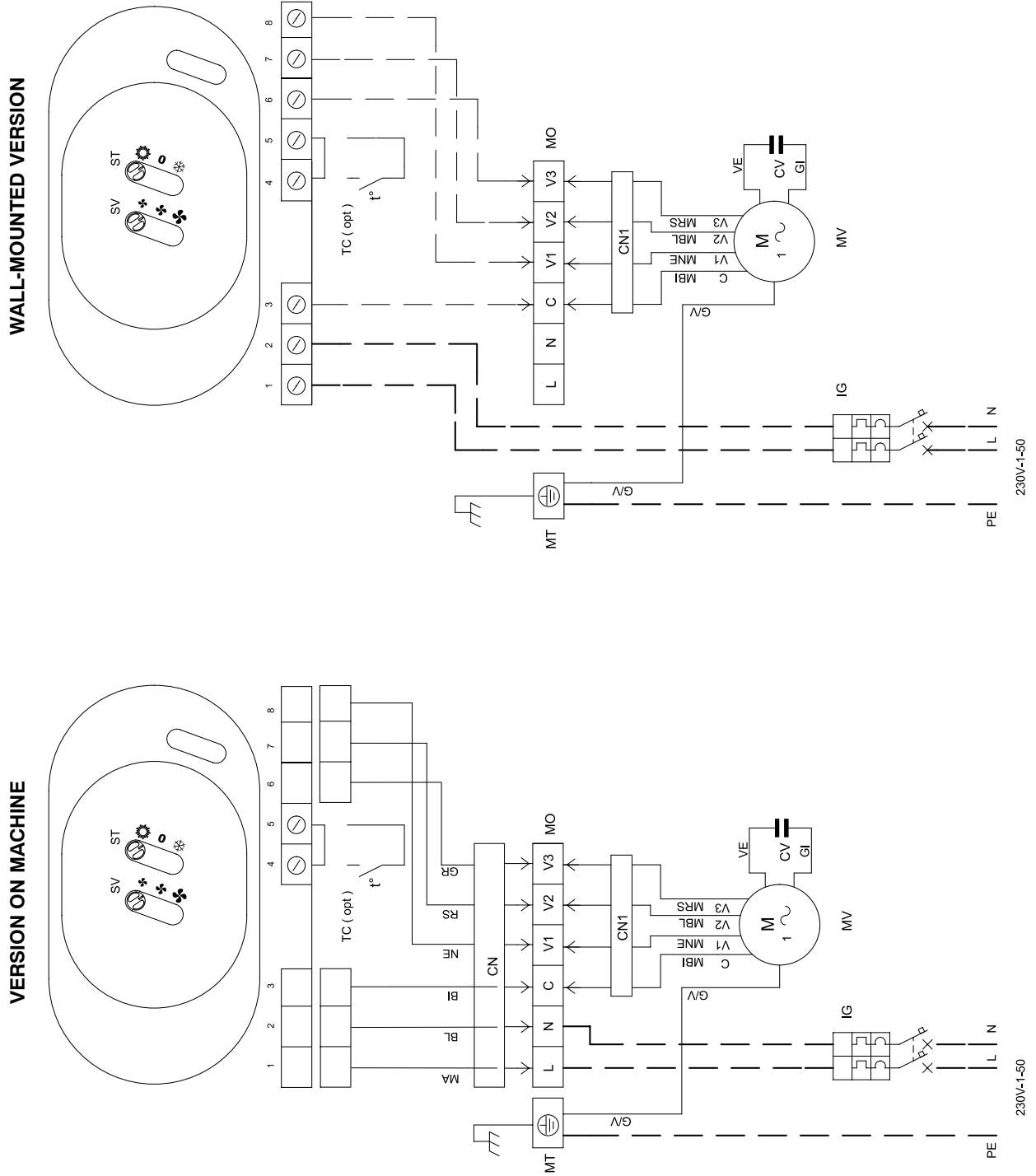

3QA09410

230V-1-50

230V-1-50

ELECTRICAL CONNECTIONS

WIRING DIAGRAMS

BASIC THERMOSTAT wiring diagram

AMBIENT THERMOSTAT - HEAT/COOL FUNCTION - SPEED SELECTOR CONTROL

WALL-MOUNTED VERSION

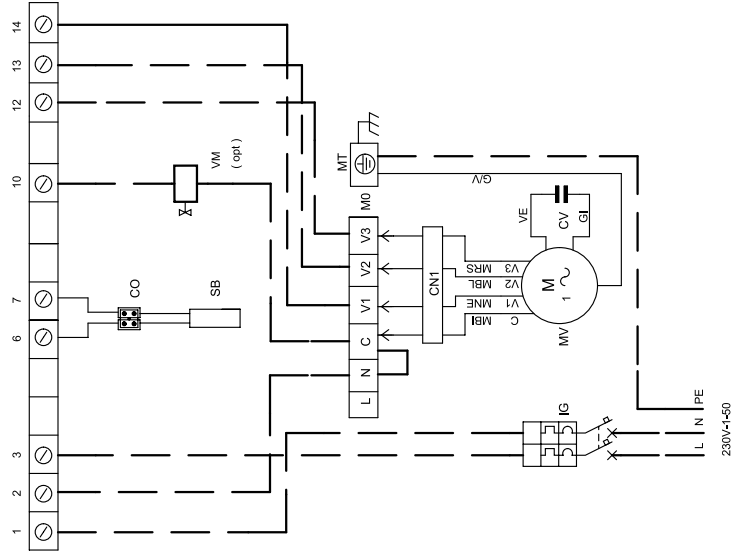
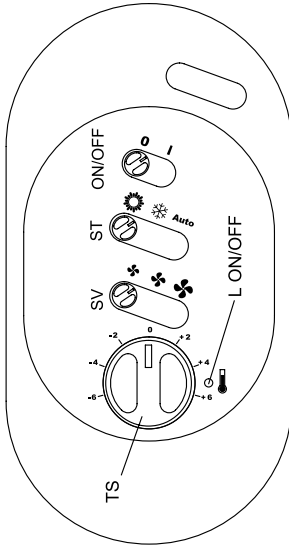

3QA09430

VERSION ON MACHINE

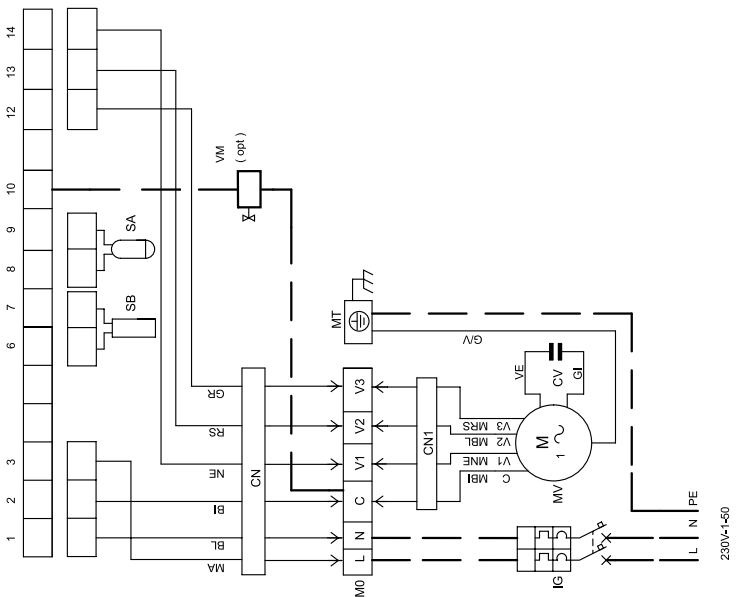
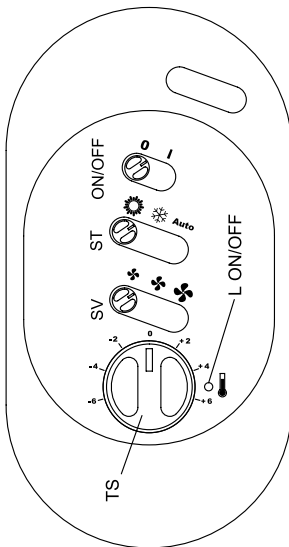

230V-1-50

ELECTRICAL CONNECTIONS

WIRING DIAGRAMS

UPGRADED THERMOSTAT wiring diagram

HEAT/COOL FUNCTION THERMOSTAT / ECONOMY - SPEED SELECTOR CONTROL

WALL-MOUNTED VERSION

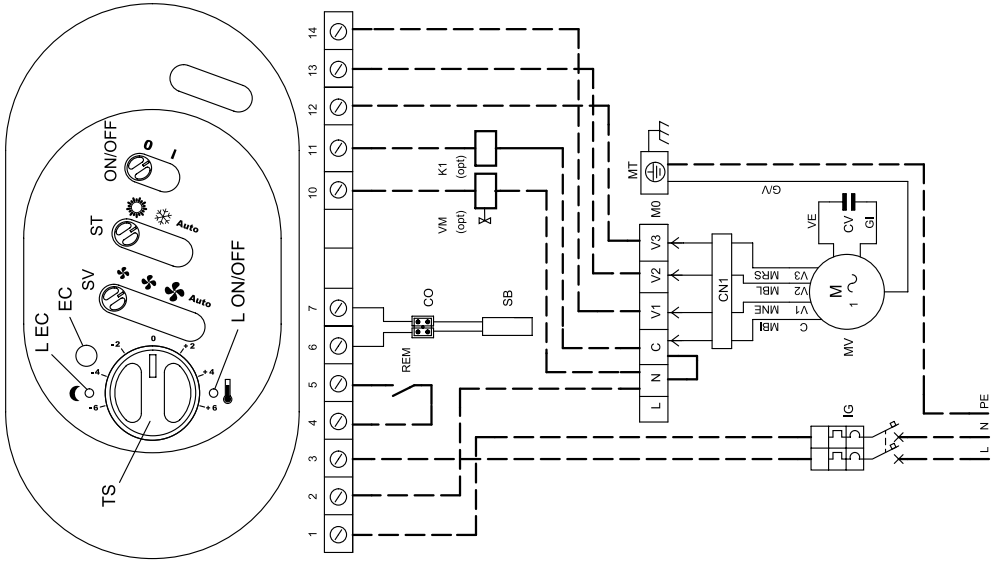

3QA09440

230V-1-50

VERSION ON MACHINE

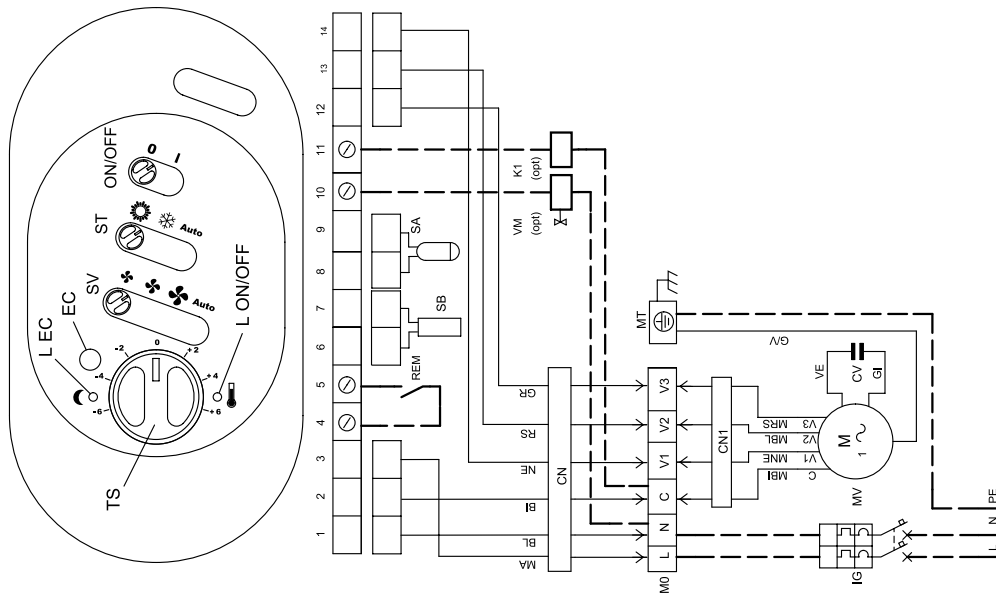

230V-1-50

The manufacturer declines all responsibility for any inaccuracies in this manual due to printing or typing errors.



FERROLI S.p.A.

Via Ritonda, 78/a - 37047 San Bonifacio
VERONA (Italy)

Tel.045/6139411 (r.a.)

Fax 045/6100233 - 6100933 - Tlx 480172